

HEBEFIX PLUS

DRAINAGE LIFTING STATION



- Unit for pre-wall installation or direct connection
- Ready to connect
- Integrated ventilation for reliable pump operation
- Flushing device against deposits in the tank
- Quiet
- Runtime monitoring with acoustic alarm and potential-free alarm contact
- Maintenance friendly
- High-quality plastic tank (ABS)

DESCRIPTION

The Hebefix plus lifting station is an easily installed appliance for disposing of faeces-free wastewater above and below the local back pressure level. Thanks to the small depth of its tank, it can be used in all commercial pre-wall systems. Its attractive design and intelligent technology also allow it to be fitted directly under a washbasin or in any other location. All grey water producers such as washbasins, showers, bathtubs, sinks, washing machines, etc. can be connected (max three applications at the same time).

The grey water is pumped to the nearest downpipe through a small-dimensioned pressure pipe (left or right side).

Hebefix plus can be used wherever an additional bathroom or kitchen is required as part of renovation or conversion work.

For acoustic failure message, the Hebefix plus contains a runtime monitoring with alarm and a potential-free alarm contact.

The unit is supplied with a submersible pump mounted (U3 variant) which is ready to be plugged to a safety socket and operates fully automatically as soon as wastewater starts to flow in. When installed in bathrooms and shower rooms, the corresponding German VDE regulations must be observed.

A sufficiently large inspection opening has to be provided for installation and servicing work (accessory). The unit is in conformity with the specifications of the German European standard EN 12050.

PERFORMANCE

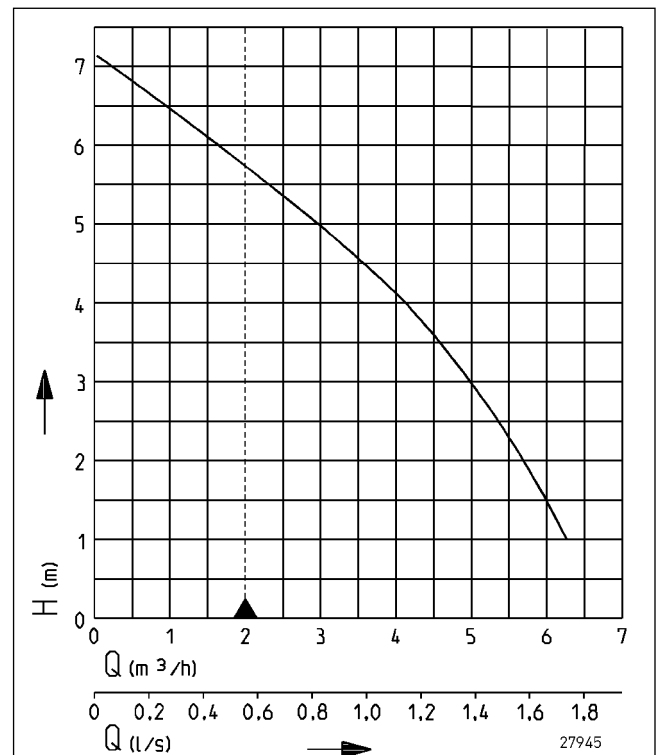

Type	Delivery head H [m]	1	2	3	4	5	6
Hebefix Plus	Flow rate Q [m³/h]	6.5	5.5	5.0	4.0	3.0	1.5

Specifications can be changed without notice. Performance subject to ISO 9906 tolerances. The minimum flow velocity in the pressure piping must be 0.7 m/s according to EN 12056. This data is represented in the performance curve as a limit of application.



HEBEFIX PLUS

DRAINAGE LIFTING STATION



SCOPE OF SUPPLY

Unit including pump according to the German European standard EN 12050, ready-to-connect with cable and plug, complete with collars, outlet elbow, swing-type checkvalve 1¼",

transition nipple, ventilation insert, activated carbon filter, clamps and fastening material.

MECHANICAL DATA

Pump	Vertical single-stage	Impeller	Vortex impeller, plastic
Free passage	10 mm	Motor housing	Stainless steel
Bearing	Ball bearings, grease-lubricated	Pump housing	Plastic
Seal on motor side	Rotary shaft seal	Submersible	Yes
Oil chamber	Yes	Pressure outlet	DN 32
Seal on medium side	Rotary shaft seal	Tank capacity	19 l
Shaft	Stainless steel	Weight	7 kg

ELECTRICAL DATA

Voltage	1/N/PE~230 V	Wires	4G0,75
Motor rating P1	0.32 kW	Type of enclosure	IP 68
Motor rating P2	0.2 kW	Insulation class	B
Current	1.4 A	Motor protection	Installed in the winding
Power line	1,5m H07RN-F	Plug	Safety

HEBEFIX PLUS

Type	Code No.
Hebefix Plus	JP44544

Dimensions Hebefix plus (mm)

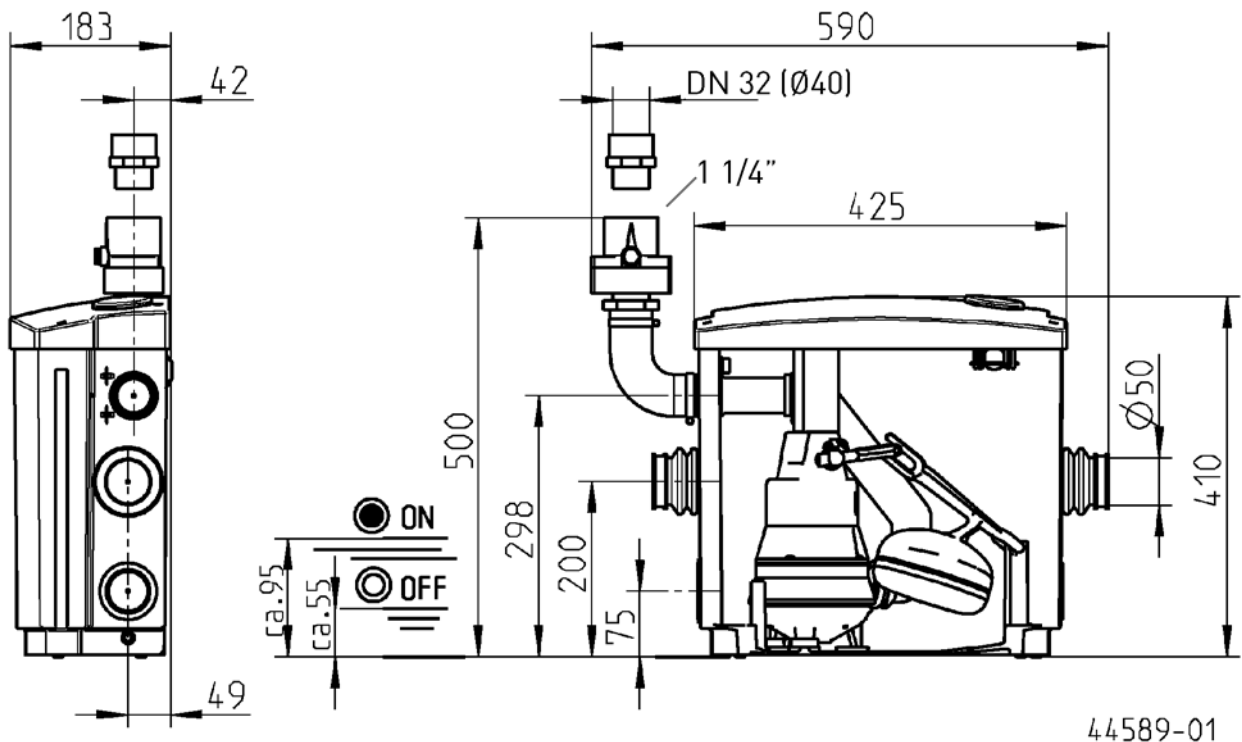

Example of installation

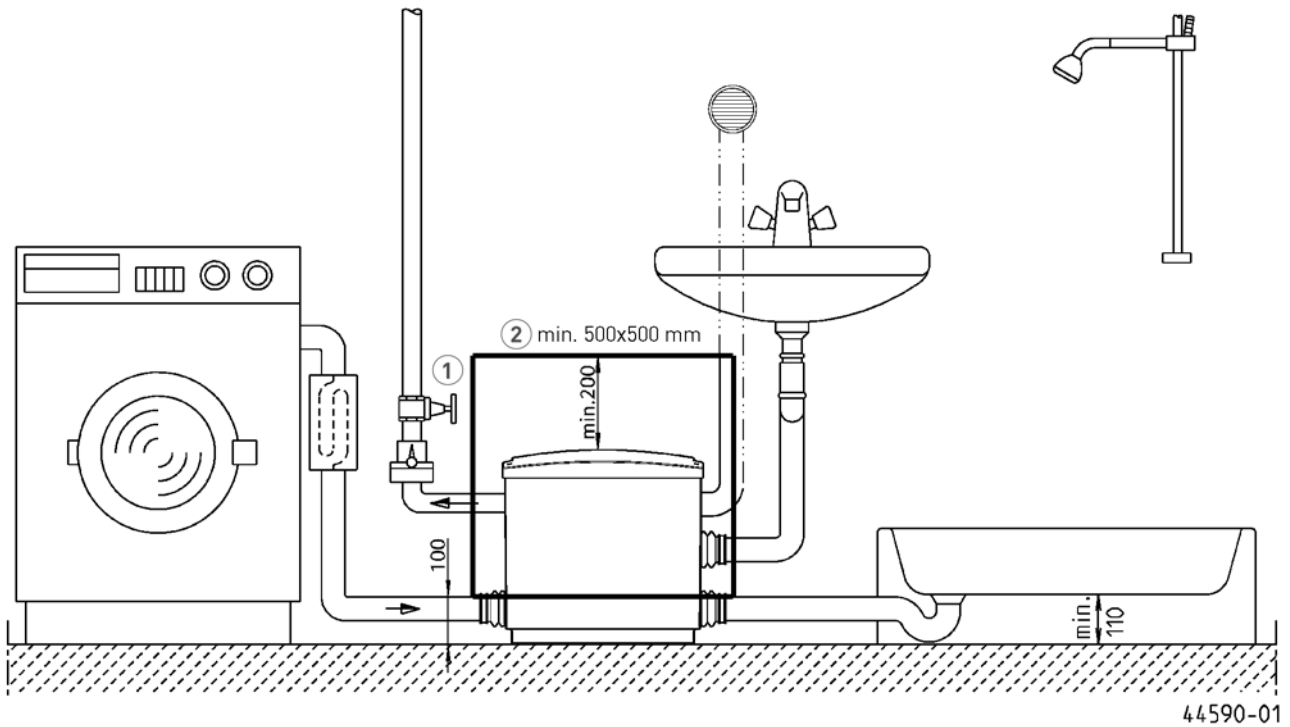

MECHANICAL ACCESSORY

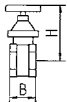
				Code No.
	① Stop valve	1/4" (DN 32), PN 16	110x60 (HxB)	JP44785
	② Installation kit	selectable size according to the tiles		JP41075