

HEBEFIX MINI
DRAINAGE LIFTING STATION

- Ready to connect
- Quiet
- Pressure-tight tank
- Hot water up to 55 °C (short-term 70 °C)
- For saline solutions up to 15 % salinity
- For condensate ≥ pH 3,0
- Wall or floor installation



DESCRIPTION

The drainage lifting station Hebefix Mini is the smallest member of our Hebefix series and can be installed quickly and easily. Thanks to its very compact design, it not only fits into all commercially available pre-wall systems, but also finds its place in a vanity unit or next to a shower. The three inlet options (2 x DN 50, 1 x DN 40) and a flexible pressure outlet in DN32 make it a small all-rounder when only limited space is available.

The Hebefix Mini can be used wherever faecal-free waste water above or below the backpressure level cannot be disposed of in gravity. Hand washbasins, showers, bidets and water softeners for detached and semi-detached houses can be connected. Condensation water from refrigerated counters and air-conditioners, condensate from gas condensing boilers as well as wastewater from dishwashers in tea kitchens (without meal) and hot water up to 55 °C (temporarily 70 °C) can also be disposed with the Hebefix Mini.

It has a pressure-tight tank, a swing-type check valve and all the necessary devices for floor or wall mounting.

The unit is ready for plug in into to a shock-proof Schuko socket. For installation in bathrooms and showers, the relevant VDE regulations must be observed.

In case of pre-wall installation, a suitable inspection opening, a tank ventilation into the operating room and an alarm system (accessory) must be provided for installation and maintenance work on the system.

PERFORMANCE

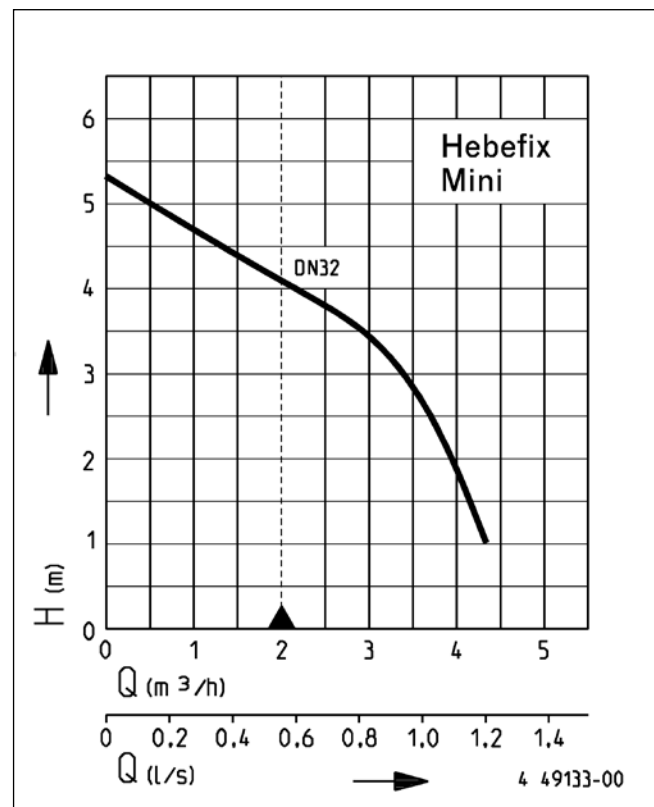

Type	Delivery head H [m]	1	2	3	4	5
Hebefix Mini	Flow rate Q [m³/h]	4.3	3.9	3.4	2.2	0.5

Specifications can be changed without notice. Performance subject to ISO 9906 tolerances. The minimum flow velocity in the pressure piping must be 0.7 m/s according to EN 12056. This data is represented in the performance curve as a limit of application.



HEBEFIX MINI

DRAINAGE LIFTING STATION



SCOPE OF SUPPLY

Unit (ABS) incl. pump and swing-type check valve according to EN 12050, ready for plug-in with 2 m cable and safety-plug, PVC fitting, flexible discharge, connecting sleeves, plug-in seals,

ventilation insert with activated carbon filter, clamps and fastening material.

MECHANICAL DATA

Pump	Vertical single-stage	Impeller	Vortex impeller, plastic
Free passage	10 mm	Motor housing	Stainless steel
Bearing	Ball bearings, grease-lubricated	Pump housing	Plastic
Seal on medium side	Mechanical seal	Submersible	No
Shaft	Stainless steel	Weight	3.9 kg

ELECTRICAL DATA

Voltage	1/N/PE~230 V	Insulation class	B
Motor rating P1	0.22 kW	Motor protection	Installed in the winding
Motor rating P2	0.11 kW	Plug	Safety
Type of enclosure	IP 44		

HEBEFIX MINI

Type	Code No.
Hebefix Mini	JP48727

Dimensions Hebefix Mini (mm)

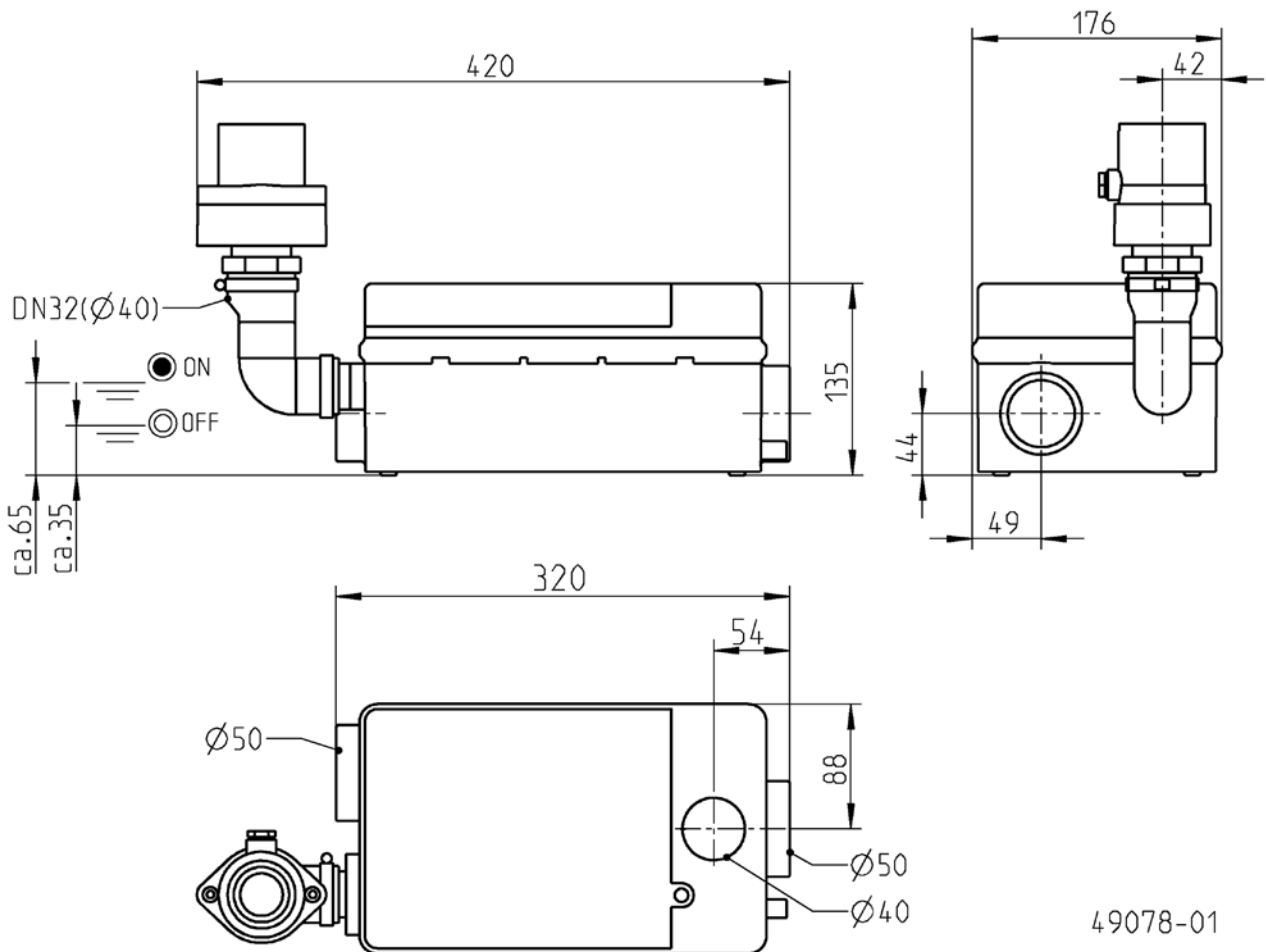

HEBEFIX MINI

DRAINAGE LIFTING STATION



Example of installation

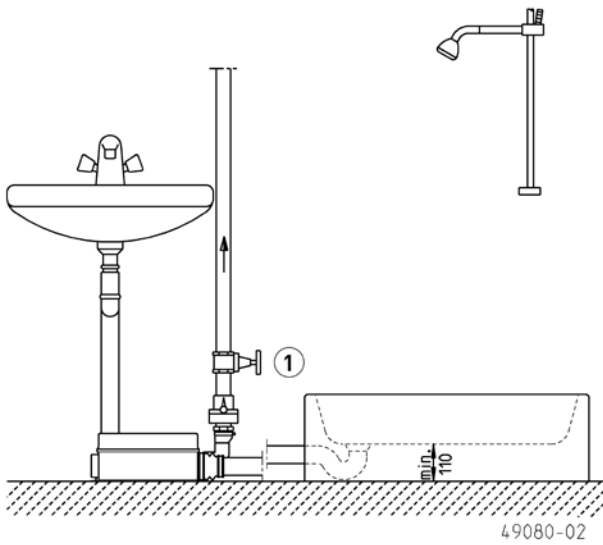

Example of pre-wall installation

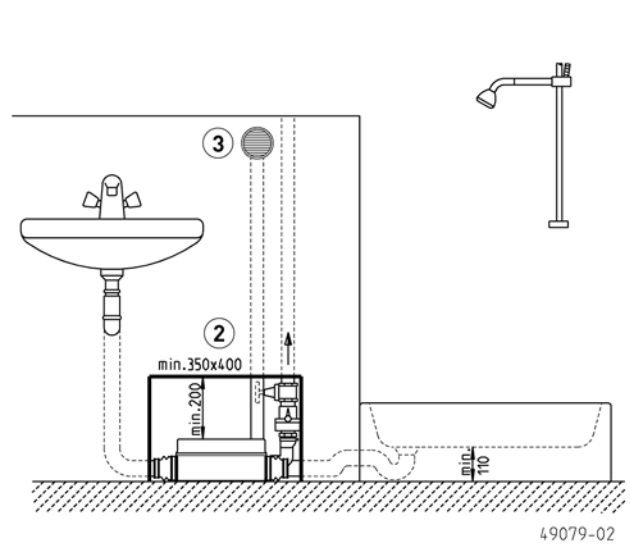

Example of water softener installation

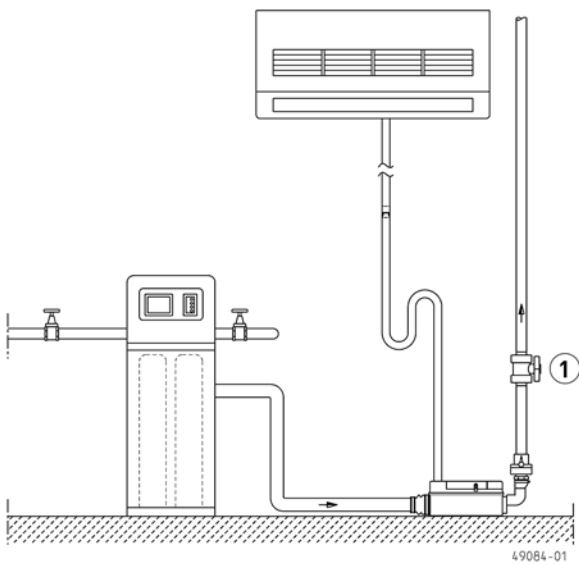

MECHANICAL ACCESSORY

			Code No.
	① Stop valve Ball valve	1¼", PVC, for aggressive media 105x155 (HxB)	JP46111
	② Installation kit	selectable size according to the tiles	JP41075
	③ Ventilation	for pre-wall installation	JP49096

ELECTRICAL ACCESSORY

			Code No.
	ⓐ Alarm unit AGR	reed switch, mains dependent, potential-free contact, 4 m cable	JP44893