

**BAUFIX 200**  
UNDERFLOOR SUMP



- Pressure stabilizer sump
- Single- or duplex unit
- Floor drain with odour trap
- Level-compensating frame
- Seal collar for attaching to the customer's thin-bed waterproofing system
- Use in groundwater areas possible
- Guide rail system GR 32 or GR 50 possible

**DESCRIPTION**

Baufix 200 is for bigger domestic wastewater volume and larger storage capacity. Without requiring a great deal of construction work, it disposes of domestic wastewater from laundries, storage or cellar areas.

Baufix 200 can be installed as a single as well as duplex system. The required components for the installation of the pump are part of the scope of supply. The duplex system provides bigger security in the disposal in wastewater. In normal operation the two pumps operate alternately or at the same time to cope with peak load.

If the system is to be operated as a single system, a pump with a built-in level control must be selected.

The pump to be placed can be selected according to the amount of wastewater. The dirty water to be transported and the pumping power required have to be taken into consideration in particular. In case of slightly dirty water, pumps U3K, U5K or U6K E+D can be used. If the admixtures are larger or the volume of wastewater is bigger, the use of a pump of the US series is recommendable. Pumps US 73+103 Ex are used in hazardous areas. In case of commercial applications, the resistance of the materials have to be tested in advance. Depending on the type of pump used, the Hebefix 200-32 with 1¼" or the Hebefix 200-50 with 2" discharge branch has to be chosen.

Without formwork, the pressure-resistant plastic PE sump is placed into the concrete bed and forms a collecting tank for underfloor pipework. The installation in areas with high ground water levels is possible without extension and under the use of the groundwater seal.

By subsequently adjusting the plastic cover frame, the sump cover can be adapted easily and variably to the floor and tile conditions.

The unit is in conformity with the specification of German / European standard DIN EN 12050.

Specifications can be changed without notice. Performance subject to ISO 9906 tolerances.

**PERFORMANCE**

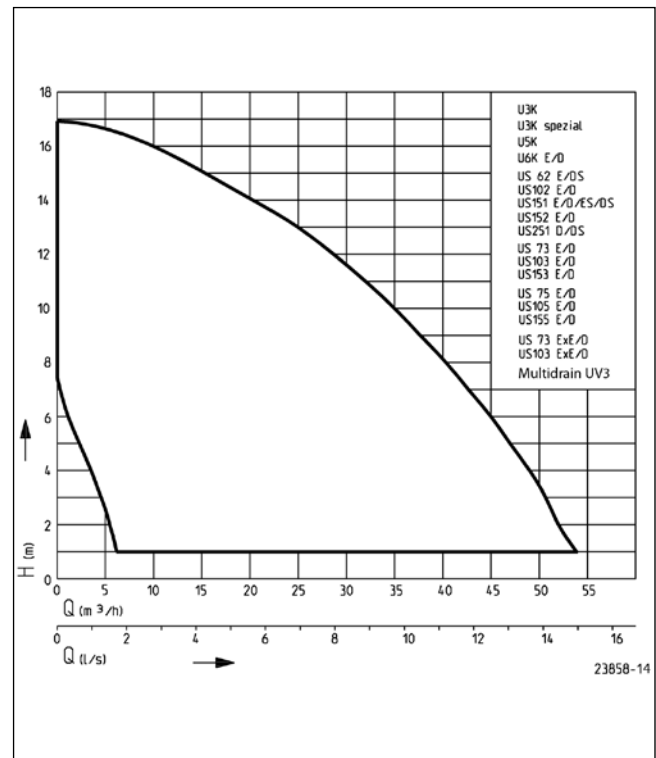

# BAUFIX 200

## UNDERFLOOR SUMP



### SCOPE OF SUPPLY

Plastic sump to house a pump tested in keeping with German/  
European standard EN 12050 with shaped connecting piece,  
level-compensating plastic cover frame, cover plate and odour

trap for floor drain, hose connection and pressure pipe, two  
swing-type check valves, plug for cable conduit, without pumps.

### MECHANICAL DATA

Tank capacity	240 l
---------------	-------

### BAUFIX 200

Type	Code No.	Weight
Baufix 200-32	<b>JP48186</b>	30 kg
Baufix 200-50	<b>JP48187</b>	37 kg

### POSSIBLE PUMPS

Baufix 200-32	US 103 E/D Ex	US 103 E/D
U3K/U3K spezial	Multidrain UV3	US 153 E/D
U5K	<b>Baufix 200-50</b>	US 75 E/D
U6K E/D	US 62 E/D	US 105 E/D
US 62 D/E	US 102 E/D	US 155 E/D
US 102 E/D	US 151 E/D	US 73 E/D Ex
US 73 E/D	US 152 E/D	US 103 E/D Ex
US 103 E/D	US 251 D	
US 73 E/D Ex	US 73 E/D	

# BAUFIX 200

## UNDERFLOOR SUMP



Dimensions Baufix 200-32 (mm)

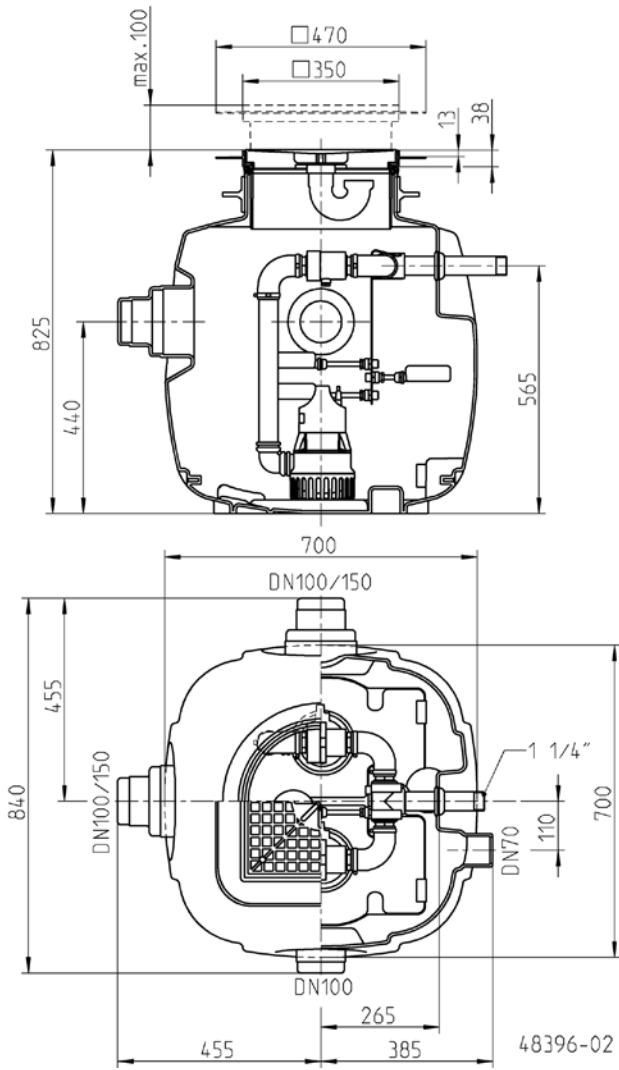



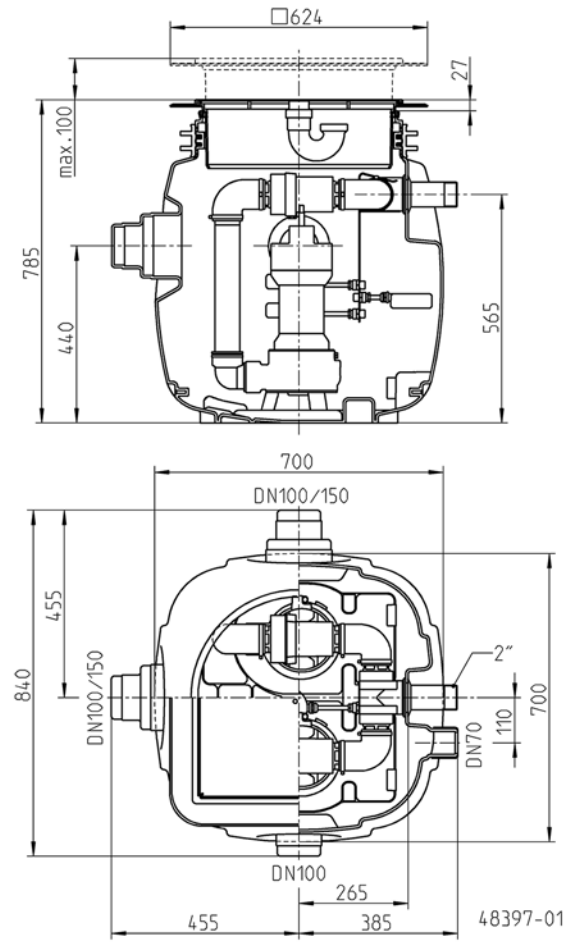

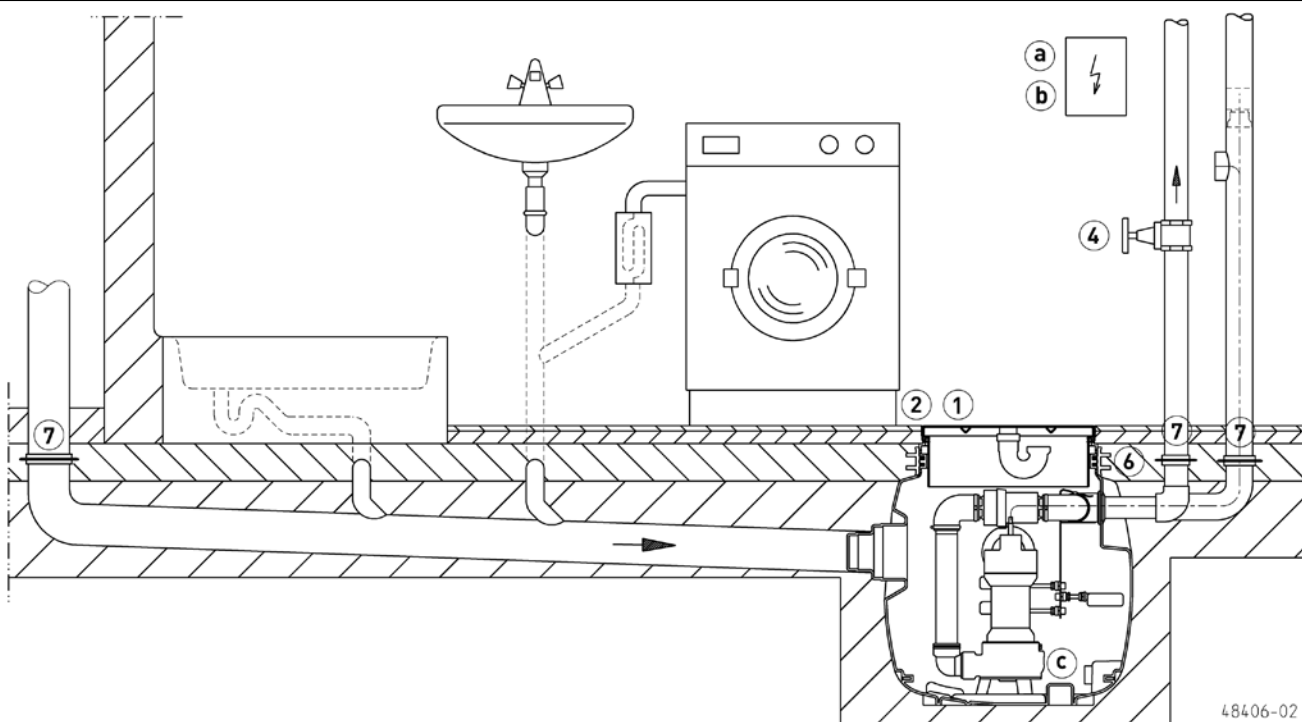

Dimensions Baufix 200-50 (mm)



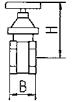

**Example of installation Baufix 200**



**MECHANICAL ACCESSORY**

				<b>Code No.</b>
	<b>1 Cover plate</b>	stainless steel, to be tiled, for Baufix 50, Baufix 100, Baufix 200-32		<b>JP24024</b>
	<b>2 Cover frame</b>	stainless steel, for Baufix 50, Baufix 100, Baufix 200-32		<b>JP28118</b>
	<b>3 Special ventilation</b>	special filter with housing, not for hot water		<b>JP27484</b>
	<b>4 Stop valve</b>	1/4" (DN 32), PN 16	110x60 (HxB)	<b>JP44785</b>
		brass, 1/2" (DN 40), PN 16	125x60 (HxB)	<b>JP44786</b>
		brass, 2" (DN 50), PN 16	140x70 (HxB)	<b>JP44787</b>
	Ball valve	1/4", PVC, for aggressive media	105x155 (HxB)	<b>JP46111</b>
	<b>5 Guide rail system</b>	Guide rail system GR32 for Hebefix 200/Baufix 200 (U3/U5/U5)		<b>JP48279</b>
		Guide rail system GR50 for Hebefix 200/Baufix 200 (US75/US105/US155)		<b>JP48280</b>
	<b>Securing levers</b>	for US 75, US 105, US 155, stainless steel		<b>JP41024</b>
	<b>6 Ground water seal sump</b>	Ø315 for Baufix 100/Baufix 200-32		<b>JP47216</b>
		Ø500 for Baufix 200-50/Vacubox 200		<b>JP48215</b>
	<b>7 Ground water seal set</b>	for Baufix 100/Baufix 200-32 with inlet DN 100		<b>JP50206</b>
		for Baufix 200-32 with inlet DN 150		<b>JP50205</b>
		for Baufix 200-50/Vacubox 200 with inlet DN 100		<b>JP50204</b>
		for Baufix 200-50/Vacubox 200 with inlet DN 150		<b>JP50203</b>
	<b>8 Sump extension</b>	165-265 mm for Baufix 200-50/Vacubox 200		<b>JP48282</b>

**ELECTRICAL ACCESSORY**

		Code No.	
	<b>a Control for duplex units</b>		
	Control unit HIGHLOGO 2-00 E	230 V	JP47996
	Control unit BD 00 E	230 V, for pumps U3-U6, US 62-105, UV3, UV 300, 08/2 ME	JP45735
	Control unit HIGHLOGO 2-00	400 V	JP47997
	Control unit BD 00	400 V, for pumps U6, US 62-105, UV 300	JP45993
	Control unit HIGHLOGO 2-25	400 V	JP47998
	Control unit BD 25	400 V, for pumps US 151-155	JP45737
	Control unit BD 610 EC	230 V, with operating capacitor	JP45743
	Control unit BD 46	400 V, for pumps US 251-253, UV 620-3, UV 625-3	JP45739
	Control unit BD 23 X	for US 73 D EX	JP09755
	Control unit BD 25 X	for US 103 D EX	JP09681
		<b>Level control</b>	
	Dry run protection	JP44603	
	Submersible switch pack B232 for Hebefix 200-32 / Baufix 200-32	JP48228	
	Submersible switch pack B250 for Hebefix 200-50 / Baufix 200-50 / Vacubox 200	JP48229	
	Submersible switch pack BF232 for grease-containing wastewater	JP48298	
	Submersible switch pack BF250 for grease-containing wastewater	JP48299	
	Auxiliary switch unit ExH-B for explosion-proof pumps only	JP00295	
	<b>Alarm unit</b>		
	AG3	subm. ball contact switch, mains dependent, potential-free contact, 3 m cable	JP44891
	AG10	subm. ball contact switch, mains dependent, potential-free contact, 9.5 m cable	JP44892
	<b>Washing machine stop</b>		
	AW3	subm. ball contact switch, mains dependent, 3 m cable	JP44895
	AW0	for alarm forwarding in case of several washing machines	JP44899
	<b>b Rechargeable battery</b>	9 V, for mains independent alarm	JP44850
	<b>c Seal leak detector</b>	DKG	JP44900
		DKG Ex for explosion-proof pumps	JP00249