

## COMPLI

1535/2 B2 HL	1555/2 B2 HL	1575/2 B5 HL	15100/2 B5 HL	15200/2 B6 HL
1525/4 C1 HL	1535/4 C1 HL	1555/4 C5 HL	1575/4 C5 HL	1575/4 B6 HL

## COMPLI

2535/2 B2 HL	2555/2 B2 HL	2575/2 B5 HL	25100/2 B5 HL	25200/2 B6 HL
2525/4 C1 HL	2535/4 C1 HL	2555/4 C5 HL	2575/4 C5 HL	2575/4 B6 HL

**DE Original-  
Betriebsanleitung**

EN Instruction Manual  
FR Instructions de service  
NL Gebruikshandleiding  
IT Istruzioni per l'uso  
PL Instrukcja eksploatacji

You have purchased a product made by Pentair Jung Pumpen and with it, therefore, also excellent quality and service. Secure this service by carrying out the installation works in accordance with the instructions, so that our product can perform its task to your complete satisfaction. Please remember that damage caused by incorrect installation or handling will adversely affect the guarantee.

This appliance can be used by children aged 8 years or over and by persons with limited physical, sensory or intellectual capabilities, or with limited experience and knowledge, provided that they are supervised or have been instructed in the safe use of the appliance and are aware of the dangers involved. Children must not be allowed to play with the appliance. Cleaning and user maintenance must not be carried out by children unless they are supervised.

If this unit is equipped with a mains connection line without a plug or other means of disconnection from the mains, a complete disconnecting device must be installed on site in the fixed electrical installation in accordance with the installation regulations. A main switch of overvoltage category III can be installed as a complete disconnecting device. If the mains connection cable of this unit is damaged, it must be replaced by the manufacturer or its customer service or a similarly qualified person in order to avoid hazards.

#### Damage prevention in case of failure

Like any other electrical device, this product may fail due to a lack of mains voltage or a technical defect.

If damage (including consequential damage) can occur as a result of product failure, the following precautions can be taken at your discretion:

- Installation of a water level dependent (under circumstances, mains-independent) alarm system, so that the alarm can be heard before damage occurs.
- Inspection of the collecting tank/chamber for tightness up to the top edge before – or at the latest, during – installation or operation of the product.
- Installation of backflow protection for drainage units that can be damaged by wastewater leakage upon product failure.
- Installation of a further product that can compensate in case of failure of the other product (e.g. duplex unit).
- Installation of an emergency power generator.

As these precautions serve to prevent or minimise consequential damage upon product failure, they are to be strictly observed as the manufacturer's guideline – in line with the standard DIN EN specifications as state of the art – when using the product (Higher Regional Court Frankfurt/Main, Ref.: 2 U 205/11, 06/15/2012).

## SAFETY INSTRUCTIONS

This instruction manual contains essential information that must be observed during installation, operation and servicing. It is therefore important that the installer and the responsible technician/operator read this instruction manual before

the equipment is installed and put into operation. The manual must always be available at the location where the pump or the plant is installed.

Failure to observe the safety instructions can lead to the loss of all indemnity.

In this instruction manual, safety information is distinctly labelled with particular symbols. Disregarding this information can be dangerous.



General danger to people



Warning of electrical voltage

**NOTICE!** Danger to equipment and operation

#### Qualification and training of personnel

All personnel involved with the operation, servicing, inspection and installation of the equipment must be suitably qualified for this work and must have studied the instruction manual in depth to ensure that they are sufficiently conversant with its contents. The supervision, competence and areas of responsibility of the personnel must be precisely regulated by the operator. If the personnel do not have the necessary skills, they must be instructed and trained accordingly.

#### Safety-conscious working

The safety instructions in this instruction manual, the existing national regulations regarding accident prevention, and any internal working, operating and safety regulations must be adhered to.

#### Safety instructions for the operator/user

All legal regulations, local directives and safety regulations must be adhered to.

The possibility of danger due to electrical energy must be prevented.

Leakages of dangerous (e.g. explosive, toxic, hot) substances must be discharged such that no danger to people or the environment occurs. Legal regulations must be observed.

#### Safety instructions for installation, inspection and maintenance works

As a basic principle, works may only be carried out to the equipment when it is shut down. Pumps or plant that convey harmful substances must be decontaminated.

All safety and protection components must be re-fitted and/or made operational immediately after the works have been completed. Their effectiveness must be checked before restarting, taking into account the current regulations and stipulations.

#### Unauthorised modifications, manufacture of spare parts

The equipment may only be modified or altered in agreement with the manufacturer. The use of original spare parts and accessories approved by the manufacturer is important for safety reasons. The use of other parts can result in liability for consequential damage being rescinded.

#### Unauthorised operating methods

The operational safety of the supplied equipment is only guaranteed if the equipment is used for its intended purpose. The limiting values given in the "Technical Data" section may not be exceeded under any circumstances.

#### Instructions regarding accident prevention

Before commencing servicing or maintenance works, cordon off the working area and check that the lifting gear is in perfect condition.

Never work alone. Always wear a hard hat, safety glasses and safety shoes and, if necessary, a suitable safety belt.

Before carrying out welding works or using electrical devices, check to ensure there is no danger of explosion.

People working in wastewater systems must be vaccinated against the pathogens that may be found there. For the sake of your health, be sure to pay meticulous attention to cleanliness wherever you are working.

Make sure that there are no toxic gases in the working area.

Observe the health and safety at work regulations and make sure that a first-aid kit is to hand.

In some cases, the pump and the pumping medium may be hot and could cause burns.

For installations in areas subject to explosion hazards, special regulations apply!

## APPLICATION

Compli sewage lifting stations are TUV certified and are suitable for lifting sewage from toilets and urinals, and domestic wastewater containing the usual impurities.

The units have a level controller that switches the pump on and off depending on the level of the water. An integrated alarm system beeps if there is a malfunction, even if this is only temporary.

If the pump overheats, the motor cuts out due to the winding thermostat. After the thermostat has switched off the system, pull out the mains plug before remedying the fault, since the device can switch itself on again automatically if the power is still connected. A direct malfunction message is not generated.

The tanks can withstand submersion to a depth of not more than 2 m of water and a submersion period of up to 7 days.

The control unit cannot withstand submersion, but is splash-proof in accordance with IP 44.

If installed in compliance with the regulations and used properly, then this control unit meets the protective requirements of the EMC Directive 2014/30/EU and is suitable for domestic use and connection to a power supply from the grid. When connected to an industrial mains within an industrial operation with power supply provided by a company-own high-voltage transformer, insufficient immunity to interference has to be expected.

When using the pumps, the relevant national laws, regulations and stipulations must be adhered to, for example:

- Sewage lifting stations for building and ground drainage systems (e.g. EN 12050 and EN 12056 in Europe)
- Installation of low voltage systems (e.g. VDE 0100 in Germany)
- Safety and working materials (e.g., BetrSichV and BGR 500 in Germany)
- Safety in wastewater systems (e.g., GUV-V C5, GUV-R 104 and GUV-R 126 in Germany)
- Electrical systems and operating resources (e.g., GUV-V A3 in Germany)
- Explosion protection EN 60079-0, EN 60079-1, EN 60079-14, EN 60079-17 and EN 1127-1

## Supply package

- One or two tanks with a DN 150 inlet clamping flange
- Two submersible drainage pumps
- Duckfoot bend for the pumps
- Flexible connector(s) with clamps for the DN 70 vent pipe
- Flexible connectors with clamps for the duckfoot bend
- Flexible connector with clamps for the pressure pipe
- Fastening materials for tank and duckfoot bend
- Control unit

## Operating mode

Intermittent operation S3; see "Technical data"

## INSTALLATION

The pump must be installed so that it is buoyancy-proof and free-standing. At least 60 cm free working space must be provided around and above the parts that require access for operation or maintenance.

Ventilation: The vent pipe must be vented above roof level.

Inlet: A wastewater stop valve must be fitted in the tank inlet.

Pressure pipe: A further wastewater sluice valve must be installed behind the EN 12050-certified swing-type check valve in the pressure pipe. The pressure pipe must be laid in a loop above the local backup level.

A pump sump must be provided to facilitate the disposal of water from the pump installation area.

Compli 1500 and Compli 2500 sewage lifting stations are supplied as assembly groups and are assembled on site by a plumbing company.

**NOTICE!** All screws and bolts that are used for fixing individual components to the tank should be tightened with a torque of no more than 6 Nm.

## Installing the tank

Close the sluice valve in the inlet (accessory) to prevent any leakage of water during the installation work.

Screw the four angle brackets to the sides of the tank. **NOTICE!** Ensure that the tank does not become deformed due to over-tightening the screws, otherwise this could result in leakage.

Slide the lifting station, together with the clamping flange, as far as possible onto the inlet pipe and then align them.

If a DN 150 side inlet is used, it must first of all be opened up at the location marked using a  $\varnothing$  152 hole saw and then deburred. The standard inlet must in this case be closed off with the sealing plug supplied.

Tighten the hexagon screws on the clamping flange.

In the case of Compli 2500, connect the two tanks together with a DN 150 pipe and clamping flanges.

Mark the position of the drill-holes for anchoring the tank to the ground, drill the holes, insert rawplugs and screw the tank in place using wood screws and washers.

## Installing the pump

**NOTICE!** In order to continue using the pump in the event of a fault or maintenance work, a maintenance valve must be fitted between each pump and the tank.

Screw three duckfeet to the underside of each bend.

Connect the bends to the tank using a flexible connector and hose clamps.

Next, bolt the bends to the floor.

Place the seals on the bends, set the pumps down on top of them and affix them from below using hexagon screws.

### Installing the ventilation

Connect the DN 70 vent pipe to the top of the tank with the flexible connector and vent it above roof level. In the case of Compli 2500, both tanks must be connected with a flexible connector but they can be brought together with a tee branch.

### Installing the pressure pipe

Attach the supports to the flanged connections (accessory) and screw them to the pumps. The remaining parts of the pressure pipe can now be assembled:

1. Swing-type check valves (accessory),
2. Stop valves (accessory)
3. "Y" piece (accessory).
4. Connect up the pressure pipe with the flexible connector and a flanged spigot (accessory) and take it in a loop over the local backup level.

### Emergency pump connection (DN 50 at front)

This connection is used for the HMP hand diaphragm pump (accessory).

Using a (∅ 38) hole saw, open up either the right-hand or left-hand pipe socket at the location marked and deburr the edges.

Fix the hand diaphragm pump to the wall at an easily accessible place and connect it to the pipe sockets on the tank with PVC piping and flexible connectors. Here, too, the pressure pipe must be looped over the local backup level.

### Mounting the control unit

**NOTICE!** Only qualified electricians may carry out electrical works to the pump or the control units.

**NOTICE!** Never put the mains plug and free lead ends in water! If water gets into the plug, this can cause malfunctions and damage.

Only operate the control unit in dry rooms and keep the housing closed at all times. The control unit must be easily accessible to enable it to be checked at any time. High humidity and condensation can destroy the controls!

For the mains electrical connection of Compli 1525, 1535, 2525 and 2535 type units, a correctly installed five pole CEE power socket is required (3/N/PEx400 V, 50 Hz). This must be located in a dry room.

For the other types, the mains power supply is connected directly to the terminals of the main switch for the control unit. The cross section of the connection cable must be configured to take into account the current input of the pumps and the length of the connection cable.

**NOTICE!** Only time delay fuses or automatic fuses with C characteristics are to be used as pre-fuses for the pump and RCD safety switches (30mA). If the pre-fuses have been triggered, the cause of the malfunction must be eliminated before switching the pump on again.

### Connecting the pumps

The pumps are connected to the control unit on site in accordance with the circuit diagram (appendix). The three-phase pumps are protected with an overcurrent release or motor protection switch, set to the rated current + 10%.

### Coil thermostats

**NOTICE!** In addition to the overcurrent release or motor protection switch, the thermostats in the motor winding must be connected to the control unit (terminal 30/32).

The thermostat contacts are suitable for a maximum of 250 V / 1.2 A (cos phi = 0.6) and are labelled 30 and 32 for connection purposes. The motor is switched off via the 230V control circuit when the response temperature is reached. The pump is switched on again automatically after the winding has cooled down.

### Connecting the level sensor

The level sensor is connected to the control unit on site in accordance with the circuit diagram (appendix).

The switch-on and switch-off points are set ex works for the standard inlet height of the respective system. In exceptional cases, however, they can be changed under the menu item "Level control".

### Alarm relays

As alarm outputs, a potential-loaded alarm relay (protected by internal control fuse F2) and a potential-free changeover contact are available.

#### External 230V~ flashing light or warning light (accessory)

Non-isolated alarm relay (230 V AC, fused with 2A slow-blow), terminals N/X2 (NO contact) or N/X3 (NC contact) The relay makes contact if there is a fault (operating current principle).

If a warning light (with bulb) is shown in the system menu, set the parameter "flashing alarm?" to "yes."

If a flashing light (with discharge bulb) is shown in the system menu, set the parameter "flashing alarm?" to "no."

#### Connecting a remote fault reporting system

- Potential-free centralised alarm relay  
The changeover contact (40-41-42) can be loaded with max. 5A/250V AC. The relay drops out with error and power failure (quiescent current principle).
- Potential-free high water relay  
The changeover contact (50-51-52) can be loaded with max. 5A/250V AC. The relay makes contact if there is a fault (operating current principle).

#### Rechargeable battery for power failure indicator

The control unit can optionally be fitted with a 9V NiMh rechargeable battery. The "BRX" jumper must be set if the buzzer is to sound.

### CAUTION!

Use only the manufacturer's 9V NiMh rechargeable batteries! There is a risk of explosion if dry-cell batteries or lithium batteries are used!

**NOTE!** Check the function of the rechargeable battery at regular intervals! The service life is about 5-10 years. Note the insertion date on the battery, and after five years the battery should be replaced as a precautionary measure.

## Test run and functional check

**NOTICE!** First of all tighten all clamps and flanged connections.

1. Open the maintenance cover on the tank.
2. Connect the lifting station to the power supply.
3. Open the sluice valves in the inlet pipe and pressure pipe.
4. Fill the tank up to the switch-on level.
5. The pump will now switch on and empty the tank. Observe the pumping process through the maintenance opening.
6. Lift the float of the level controller slowly by hand until it is above the switch-on point and hold it there until the alarm is triggered
7. Then close the maintenance opening with the cover and seal.
8. Check to ensure that the tank, fittings and pipes are water-tight, by carrying out several switching runs.

## OPERATION

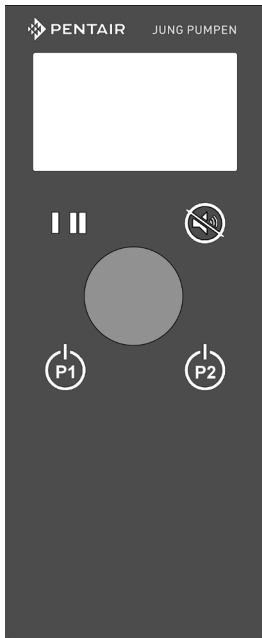

Display

LED pump 1 and pump 2  
Acknowledgement button and menu exit

OK Rotary knob  
Select = turn,  
Acknowledge = press

Manual-0-automatic  
Pump 1 and pump 2

The control unit has a graphic LCD display. The data is evaluated and updated at short intervals, which can sometimes look like flickering. The backlighting is activated for a limited time by pressing a button. The contrast can be changed in the system settings menu item.

It is operated with a rotary knob and three membrane keys: an acknowledgement button and manual-0-automatic buttons for the pump(s).

The two LEDs show the operating status of the pumps:

- Continuous green light = Operational
- Green flashing - Pump in operation
- Continuous red light = Fault
- Red flashing - Fault, pump in operation
- Orange = Maintenance due

## Operating modes

In addition to the automatic operating mode described above, each pump can also be switched on and off manually using the operating button.

The operating status of the control unit is shown in the display;

the existing operating mode is highlighted as a negative image.

### MANUAL/ON

The pump continues to run in manual mode until a different operating mode is selected. However, if there is dry-running protection, this will take priority over the manual switching. The pump must be switched off before it starts to draw in air! Otherwise, the pump will require bleeding to discharge the air!

### OFF

The pump is switched off and remains off until a different operating mode is selected. It will remain off even if a high-water situation occurs.

### AUTO

The pumps are switched on and off by the control unit depending on the water level. However, if there is dry-running protection, this will take priority over the automatic switching.

**NOTE!** If the control unit is password-protected, the password must first be entered under "Settings" to change the operating mode.

### **WARNING!**

For repair and maintenance work on pumps or control units, do not use the "Off" function, but always de-energize the system by unscrewing the back-up fuses or via a main switch and secure against being switched on again!

**NOTICE!** If unusually large quantities of wastewater flow into the unit (e.g. when a pool is drained), partially close the shut-off valve at the inlet until the unit can operate normally again, switching on and off, (S3 Intermittent duty, not pumping continuously, since this could overheat the pump motor).

## Inspection

To maintain operational reliability, carry out a visual inspection of the unit, including the pipe connections, once a month.

## Faults / alarm

Faults are signalled via the red LED, a built-in buzzer, a non-isolated relay "Alarm", a potential-free relay "Centralised alarm" and a potential-free relay "High water".

The relay "Centralised alarm signal" can be delayed up to 60 minutes in order not to trigger an alarm if there is a short-term high water level. The deployment of a service technician would be unnecessary in this case.

The fault text is shown in the display and alternates with the standard display text. If more than one fault has occurred, the relevant messages will be shown consecutively in the display. In addition, the high water alarm is reported to a separate potential-free relay.

## OPERATION

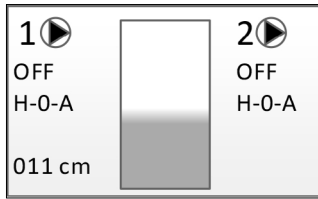

The standard display shows the operating mode of the control unit, the switching status, the motor current and the level.

To enter the menu, turn the rotary knob to the right.

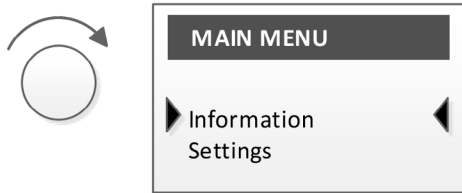

## INFORMATION

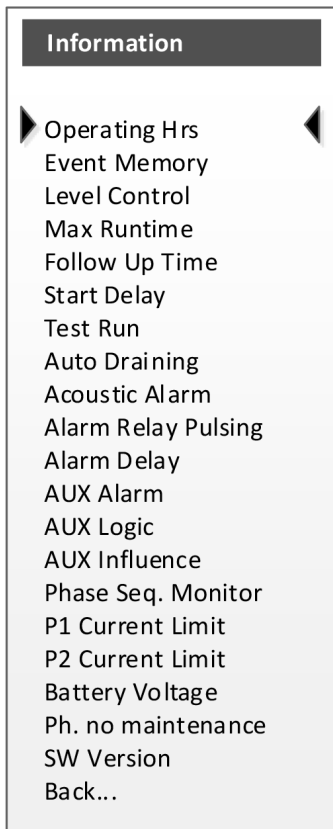

- Operating hours  
Displays the operating hours per pump and the pump switching cycles
- Event memory  
Shows the error messages of the system. The newest message is at the top, older ones below. After 70 messages, the oldest message is deleted from the memory.
- Level control  
Displays the level control system that is set
- Max. runtime  
Displays the running time limit that has been set for the pumps (S2/S3 time)
- Follow-up Time  
Displays the follow-up time that has been set for static pressure systems
- Start delay  
Display the period of time that has been set between supplying power supply and being operational
- Test run  
Displays whether the test run is activated
- Auto draining  
Displays the interval that has been set for the automatic pumping procedure in analogue systems, to prevent long stationary periods
- Acoustic alarm  
Displays whether the buzzer is activated
- Alarm relay pulsing  
Shows whether the relay works in cycles in the event of an alarm or whether it is continuously energised
- Alarm delay  
Shows currently set delay for alarm relay
- AUX alarm  
Shows whether the signalling is switched on or off
- AUX logic  
Shows whether the auxiliary input works as an NC contact or an NO contact
- AUX influence  
Shows, what influence the auxiliary input as on the pumps
- Phase seq. monitor  
Shows whether the check on the direction of rotation is activated
- P1 current limit  
Shows the current limitation that has been set for pump 1
- P2 current limit  
Shows the current limitation that has been set for pump 2
- Battery voltage  
Displays the voltage of the 12 V battery (only with accessory RTC module)
- Maintenance service  
Call number of the responsible customer service
- SW Version  
Shows the current software version

## SETTINGS

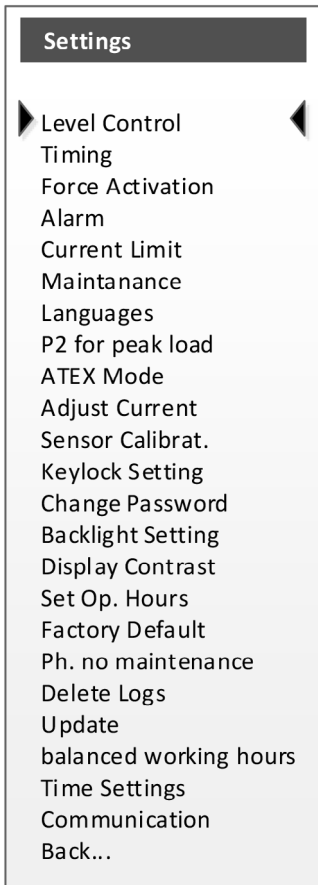

If you wish to change a parameter in this system menu, you will be asked to enter a password (4-digit number).

**NOTE!** The password is set to "3197" in the factory. If the password is changed and then forgotten, the device must be re-activated by the manufacturer's customer service department. It is not possible for the user to reset the system!

If more than about one minute passes in the system menu without any entry being made, the control unit automatically switches back to the standard display.

**NOTE!** Only the menu items relevant to Compli lifting systems are described.

### Level Control

The different types can be selected here. The switching levels for the various lifting stations are already pre-set. In exceptional cases, however, they can be changed under this menu item.

### Timing

#### Max running time

The running time of the pump can be restricted to a maximum duration. This function is necessary for short duration operation or intermittent duty operation (S2 and S3 operation) of the pump.

The times are dependent on the type of pump and can be found in the technical data provided with the pump. If the pump runs

continuously for longer than the time specified here, an alarm will be triggered.

The maximum runtime monitoring is only active in ATEX mode and can be reset after it has been triggered by the acknowledgement button. If the acknowledgement button is not pressed, an automatic reset occurs at the S2 time after 7 times the triggering time and at the S3 time triggering after the S3 pause time.

- S2 time [Short-time operation]

When the pump is not submerged, it operates only for a pre-set period (maximum running time 1 to 120 minutes). This is to prevent the temperature of the motor from rising above its maximal permissible operating temperature. The value for the maximum permissible running time can be found in the technical data provided with the pump. The subsequent pause time (restart lock-out), during which the pump remains switched off, must be long enough to allow the motor to cool down to the ambient temperature. This is generally equal to the operating time multiplied by a factor of seven.

- S3 time (intermittent duty)

The pump operates only for a short period before being switched off again if it is not submerged. The switch-on and switch-off times are expressed as percentages of 10 minutes, e.g. for an S3 time of 30%, the pump is switched on for not longer than 3 minutes and then switched off for 7 minutes. This operating mode ensures that the pump does not overheat.

- Deactivated

The S2/S3 time monitoring can be deactivated here

#### Start-up delay

In order to avoid mains disturbances in areas with many pumping stations, the control unit is equipped with a variable start-up delay. The delay time can be set from 0 to 300 seconds.

### Force activation

### Alarm

In this menu all settings for the buzzer and the alarm relays are made.

#### Acoustic alarm

If this function is deactivated, only the integrated alarm buzzer is switched off.

Options: Off/on.

If a fault is acknowledged, the buzzer stops and the non-isolated relay drops out. However, the potential-free relay contacts remain active. If the Acknowledge button is then pressed again and the fault is no longer present, these relays are also reset to their original position.

An external alarm acknowledgement is possible via terminals 14/15.

#### Alarm relay flashes

You are able to select here whether the non-isolated alarm relay switches at one-second intervals when a fault occurs or whether it remains on all the time: On = switches on every second, Off = permanently on.

An alarm delay also affects this relay.

## Delay alarm

**NOTE!** No alarm delay is available in 9V battery operation.

In order not to trigger an alarm immediately with short-term events, a delay can be set for the switching of the alarm contacts.

Setting range from 1 to 3600 seconds. A value of 0 deactivates this function!

- Centralised alarmtime-delayed acoustic alarm and the relay drops out with a time delay.
- High water alarm
  - Analogue level detection: the relay makes contact with a delay

## AUX Alarm

The AUX alarm can be switched on and off here.

## AUX logic

**NOTE!** Non-isolated contacts can cause damage to the control unit.

Only potential-free digital contacts such as rain sensors, external interlocks with other pumping stations or RCD switch auxiliary contacts may be connected to the Aux input.

The switching logic can be selected as NC contact or NO contact.

**NOTE!** Locked pumps also start with a high water alarm.

## AUX influence

"Aux influence" can be used to select whether an alarm switches off one or both pumps ("P1 OFF", "P2 OFF" or "Both OFF") or does not have any effect ("None"). In either case, the triggered alarm appears in the display and activates the potential-free and non-isolated alarm relays as soon as the pre-set alarm delay time has expired.

## Direction of rotation check

Monitoring of the rotational direction can be activated in this menu. An alarm is triggered if a phase failure or if an anticlockwise rotating field is detected.

Options "On" and "Off".

This function is activated as standard and does not need to be deactivated when supplied with AC power.

## Buzzer reactivation

After a buzzer acknowledgement, the alarm is automatically reactivated if the fault persists for another 4 / 8 / 12 hours. Factory default setting: 4 hours.

## External relay

This menu item is enabled when the optional module for individual fault messages D02 or D06 is connected.

For each relay it is selected whether operating current or quiescent current principle and which faults trigger the relay.

## Current limit

In this menu, the maximum motor current can be entered. This value will be compared with the measured motor current. If the measured motor current is higher than the entered maximum motor current, the motor is switched off depending on a

simulated time-current characteristic of the motor protection relay.

## Maintenance

Setting the next maintenance reminder after 90/180/365 days or OFF.

Additional input possibility of the last maintenance, format DD.MM.YYYY. The input is only an information text and has no influence on switching functions.

## Languages

Setting the menu language German, English, Finnish, French, Dutch, Italian, Polish or Swedish.

## P2 for peak load

Setting option On / Off

When "ON", the pump at rest is switched on when the peak load level is reached.

When "OFF", the pump switches once to the idle pump when the peak load level is reached.

## ATEX mode

## Adjust current

Only for the manufacturer's Customer Service.

## Sensor calibration

For readjustment, fill the container (fill level of the respective type see appendix) and then select this menu item "Sensor calibration".

Calibration is performed automatically when 20s have elapsed or the OK button is pressed. The calibration can be aborted by pressing the acknowledge button prematurely.

## Keylock setting

All settings and the operating mode selection Manual-0-Automatic can be locked. The lock is automatically activated after one minute.

- Key lock off (remove all locks)
- Unlock key: to unlock, press the acknowledgement button for at least 3 seconds
- Unlock password: enter password to unlock

## Change password

The password for the setting menu can be changed here; the factory setting is 3197.

## Backlight setting

Auto OFF - Backlighting is switched off after 1 minute  
Always ON - Backlighting is always ON.



## Display contrast

The contrast can be changed using the bar display.

## Set operating hours

P1 Op. hrs P1 Cycles

P2 Op. hrs P2 Cycles

Here the operating hours (Op. hrs) or the switching cycles can be adjusted. (when replacing the control unit or installing a used pump.)

## Factory default

Resets the control unit to the factory settings. The existing configuration, all event messages and operating data will be overwritten. At the next start-up, the initial commissioning menu will be displayed.

## Maintenance service

The phone number for the appropriate Customer Service can be deposited here.

## Update

Only for calling the manufacturer's Customer Service.

## Balanced working hours

If this menu item is active, the pump with the lowest operating hours is always selected.

## Time settings

Only for RTC module accessories: Time and date can be set.

## Communication

Only with accessory "GSM module": Communication settings can be made.

## ERROR MESSAGES

**Rotational field error.** There is no clockwise rotating field, one phase is missing or the neutral conductor is not connected.

**High water alarm.** This error message is shown if the level of water measured lies above the pre-set alarm level or if the high-water float switch is triggered. The pump is then switched on, provided that there is no fault of the pump.

**Error Aux.** The auxiliary input has been activated. The consequences for the pump control unit depends on the configuration.

**Motor protection.** The motor protection switch or the motor protection relay of the pump has triggered. The pump is then switched off. If the error condition no longer exists, the control unit starts up again. This error condition will also be saved in the event of a power failure. The message is saved in the EEPROM of the processor, which is zero voltage safe.

**Overcurrent.** If the measured motor current (current transformer measurement on the board) is above the entered maximum motor current, the pump is switched off depending on a simulated time-current characteristic of the motor protection relay. After 30 seconds an automatic reset is performed. **NOTE!** This function does not replace the mechanical motor protection switch or the overcurrent relay!

**Thermostat.** The pump's thermal contact has been triggered. The pump is then switched off.

The pump starts automatically once the thermostat has cooled down.

**Running time.** The maximum running time of the pump has been exceeded.

## MAINTENANCE

Maintenance and inspection of this product must be carried out in accordance with EN 12056-4. To ensure continued reliability of service, we recommend that you take out a service contract.

**NOTICE!** The maintenance of the sewage lifting station and maintenance measures are carried out by specialists at intervals of 3 months in commercial premises, multi-family homes in 6 months or 12 months in family homes.



### WARNING!

Before carrying out any works: disconnect the pump and the controls from the mains and take steps to ensure that they cannot be energized again.



### WARNING!

Check the cable for mechanical or chemical damage. Damaged or kinked cables must be replaced by the manufacturer.

We recommend that the following works be included in the service:

1. Check the connection points for watertightness and inspect the areas surrounding the unit and the fittings.
2. Operate the shut-off valves and check that they move easily. Adjust and grease them if necessary.
3. Open and clean the swing-type check valve; check the seat and valve (ball)
4. Clean the pump and the pipes where they connect to the unit; check the impeller and the bearings.



### CAUTION!

Worn impellers can have sharp edges.

5. Oil check. If necessary top up or change oil (if oil chamber available).
6. Clean the inside of the tank (as necessary, or if especially required); remove any grease, for example.
7. Check the condition of the collecting tank.
8. Flush the system through with water once every 2 years.
9. Inspect the electrical section of the unit. The control unit itself is maintenance-free, but if a rechargeable battery is fitted, then it should be checked regularly to ensure that it is in good working order. To do so, unplug the unit from the mains and lift the float of the level controller slowly by hand and hold it there until the alarm is triggered.

10. In addition, clean the float if necessary.

When all the servicing tasks have been performed, carry out a test run and then put the unit back into operation. The service must be documented, giving details of the important data and of all the tasks carried out.

### Oil check

First of all, unscrew the hexagon screws or Allen screws around the pump and lift the pump and impeller off the tank. The drain plug is labelled "Öl". In order to check the mechanical seal, the oil, including any residue, must be drained from the oil reservoir and collected in a clean measuring container.

- If the oil is contaminated with water (milky), an oil change must be carried out. Check again after a further 300 operating hours, but at the very latest after 6 months!
- However, if the oil is contaminated with both water and pollutants, then not only the oil must be replaced, but the mechanical seal as well.

For monitoring the oil reservoir, it is also possible to retrofit the electrode of our "DKG" seal leak detector in place of the "DKG" sealing screw.

### Changing the oil

To ensure operational liability, the first oil change should be carried out after 300 operating hours, with further oil changes carried out after every 1000 operating hours.

If the number of operating hours is very low, an oil change should still be carried out at least once a year.

If wastewater with strongly abrasive constituents is being pumped, the oil changes should be carried out at correspondingly shorter intervals.

Use HLP hydraulic mineral oil, viscosity class 22 to 46, e.g. Mobil DTE 22, DTE 24, DTE 25, to replace the oil in the oil reservoir.

Quantity: **700 cm<sup>3</sup>** (1525/..., 1535/..., 2525/..., 2535/...), **1300 cm<sup>3</sup>** (1555/..., 1575/..., 15100/..., 2555/..., 2575/..., 25100/...) or **6800 cm<sup>3</sup>** (15200/..., 25200/...).

**NOTICE!** The oil reservoir may only be filled with the specified quantity of oil. Overfilling will result in the pump being rendered inoperable.

## QUICK TIPS FOR REMEDYING FAULTS

### WARNING!

Before carrying out any work: Disconnect the pump(s) and the control unit from the mains by unscrewing and taking out the pre-fuses, and take action to ensure that no one else can reconnect them to the power supply.

**NOTE!** Work on the control unit must be carried out by qualified electricians only!

- System does not work either in automatic or manual mode.
  - No mains power; check fuses and RCD switch, the operating mode for the pump should not be set to "0".
- System does not work, "Pump motor protection" is displayed
  - The motor protection relay or the motor protection switch has switched off. Check motor protection settings and set the rated power for the pump. Acknowledge with the acknowledge button and reset the motor protection switch by hand.
- Motor protection shuts off after only a short time
  - Pump impeller blocked -> Clean (refer to pump manual)
  - Motor contactor does not switch through all phases-> Replace
  - Motor fault -> Call customer service personnel
- Backpressure, water rising slowly
  - Intake line blocked -> Clean and unblock.
- Pump delivers too little, high water alarm
  - Check gate valve in pressure pipe and open completely, clean non-return valve and flush out pressure line.
- Pump thermostat
  - Let the pump cool down, and acknowledge with the OK button.
- Display does not show any readings
  - No mains power; check fuses and RCD switch, switch on the main switch if necessary.
- Green LED does not light up
  - No mains power, check fuses and RCD switch, switch on main switch if necessary, operating mode of the pump must not be set to "0".
- Red LED lights up
  - The fault is shown in the display; then confirm with the acknowledge button.
- No access to the menu
  - Password incorrect.

## TECHNICAL DATA

Weight	depending on type 4-6 kg
Protection category	IP 44
Operating voltage	3/N/PE x 400 V, 50 Hz
Power consumption of control unit	approx. 8 W
Control fuse	F1 fine-wire fuse 5x20 mm, 6.3 A T/MT; EN 60127-2-5, DIN 41571-2
Fuse alternating current output	F2 fine-wire fuse 5x20 mm, 2.0 A T/MT; EN 60127-2-5, DIN 41571-2
High water alarm emergency supply (optional)	9 V NiMH rechargeable batteries
Terminals	2.5 mm <sup>2</sup> push-in terminals on the PCB 4 mm <sup>2</sup> push-in terminals on top hat rail Screw terminals 4 mm <sup>2</sup> at the motor protection relay/motor contactor Screw terminal 6/10 mm <sup>2</sup> for potential equalisation
Motor protection	Motor protection switch on top hat rail / motor protection relay on contactor
Monitoring of rotational field / phase failure	Error message given for anti-clockwise rotating field and if there is a power phase failure
Temperature range in operation	-20 ... 50°C
Temperature range in storage	-20 ... 70°C
Air humidity	0 to 90% RH, with no condensation
Compli potentiometer	5 kOhm
Level switch, input	24 V, 4 mA
High water alarm, input	12 V, 7 mA
Powered alarm relay	230 V AC, max 2 A (AC1)
Potential-free alarm relay	5A, 250 V AC
Method used for measuring current	via current transformer and A/D converter
Current transformer	0 - 20 A, ± 10%

Parameter	Factory default setting	Client setting
-----------	-------------------------	----------------

**Level detection**

Level detection	Compli	
base load ON	depending on analogue level detection	
Base load OFF	depending on analogue level detection	
peak load ON	depending on analogue level detection	
Peak load OFF	depending on analogue level detection	
High water	depending on analogue level detection	
Upper edge of pump	depending on analogue level detection	

**Time control**

Max. running time	Deactivated	
S2 Short-time operation	10 Min	
S3 Intermittent duty	10%	
Follow-up time	Standard / 6 s	
Start-up delay	0 s	

**Forced switching on**

Test run	OFF	
Auto. Pumping out	000 h	

**Alarm**

Acoustic alarm	ON	
Alarm relay flashes	OFF	
Delay alarm	0 s	
AUX logic	NO contact	
AUX influence	None	
Direction of rotation check	Activated	
Buzzer reactivation	4 hours	
Overcurrent limit		
P1 Current limit	0 = deactivated	
P2 Current limit	0 = deactivated	
Maintenance		
Days	365 days	
Last maintenance	01/01/2016	

**Further settings**

P2 Peak load	ON	
ATEX mode	OFF	
Compensate for operating hours	NO	
Lock setting	Key lock OFF	
Change the password	3197 <User must first confirm old password>	
Light settings	Auto OFF	
Maintenance service	01805 188881	

Parameter	Factory default setting	Client setting
-----------	-------------------------	----------------

**Communication**

SIM card PIN no.		
Cell phone provider		
APN	APN.com	
Authentication		
User name		
Password		
Receiver SMS1		
Receiver SMS2		
Receiver SMS3		
SMS acknowledgement	OFF	
SMS response time	5 minutes	
Routine messages	10 days at 8:00	
Additional call for SMS	OFF	
Station ID	SGJU4	
Station name	PENTAIR-HighLogo	

**Error transmission**

△ Start error		
▽ Error end		
E-mail address 1		
E-mail address 2		
E-mail address 3		

**E-mail settings**

SMTP server	smtp.gmail.com	
Port	465	
Encryption	Yes	
User ID		
Password		

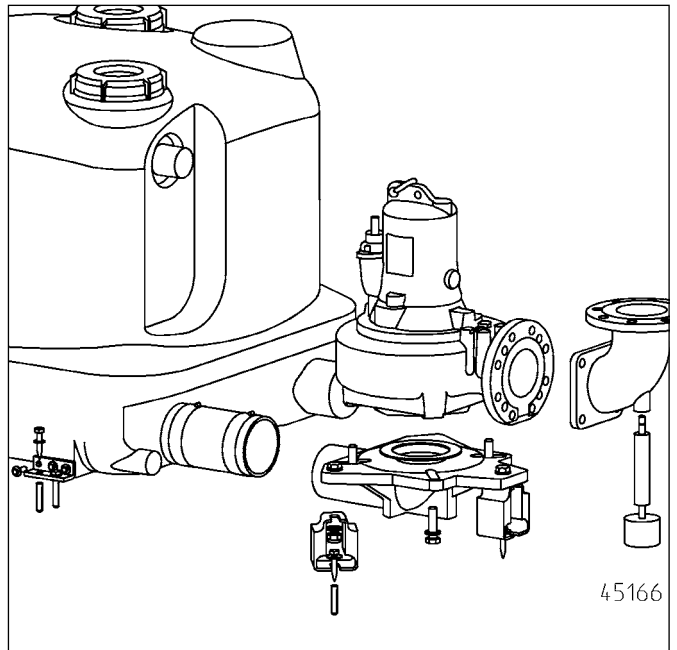
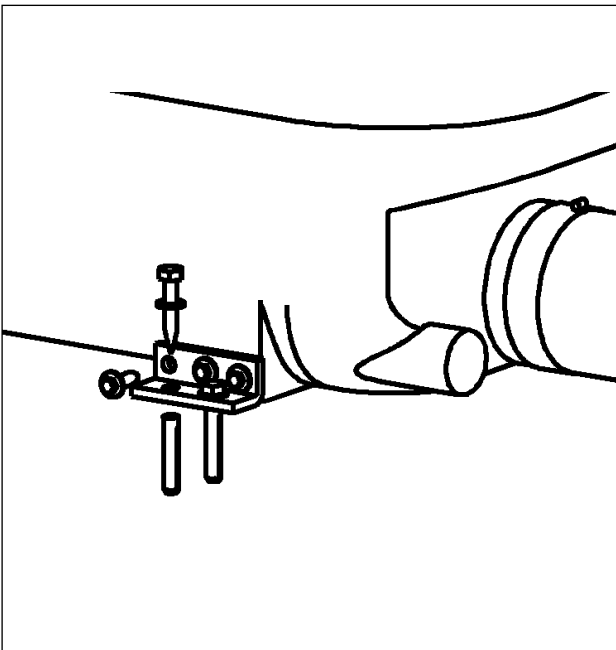
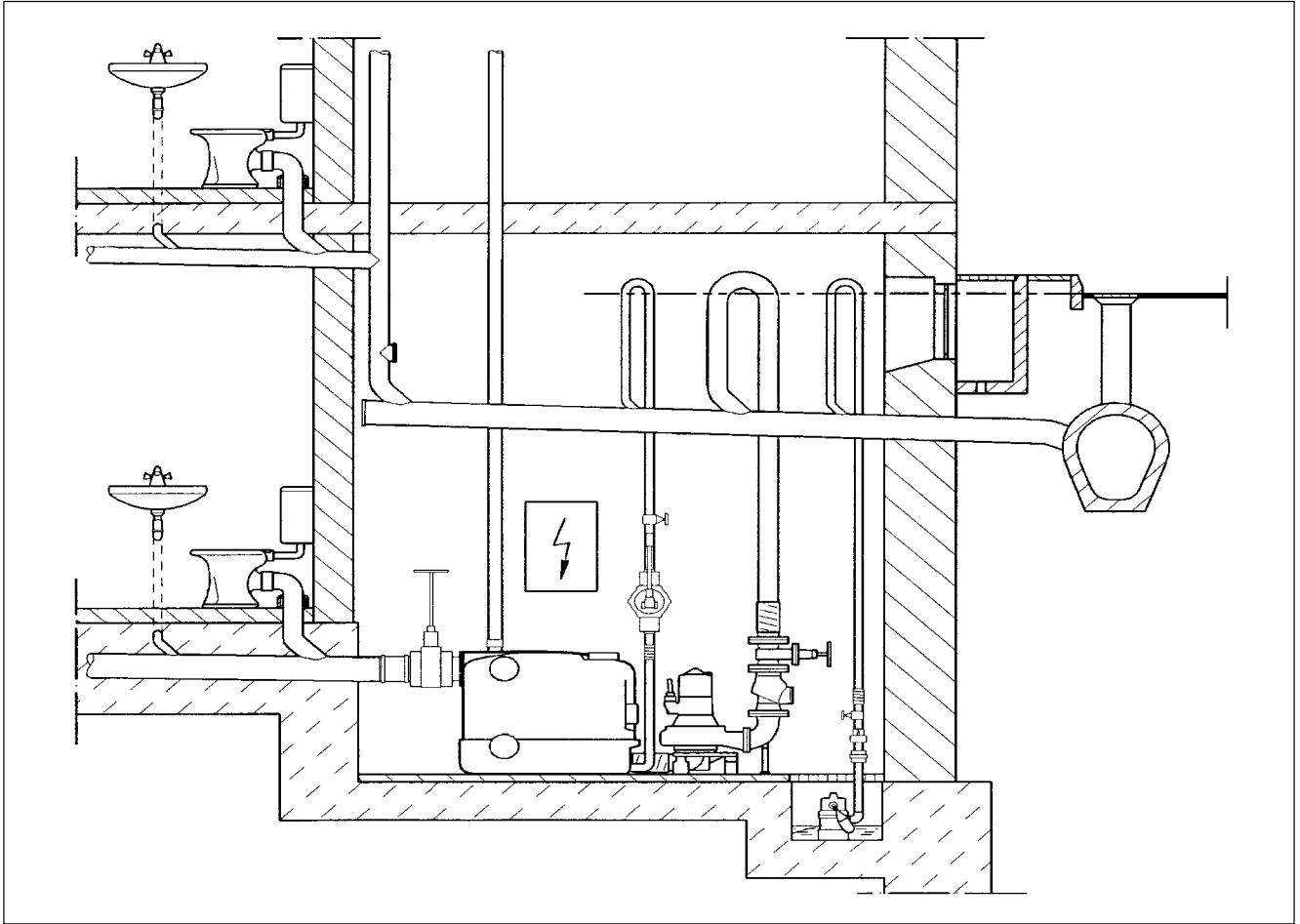

**Compli 1500**

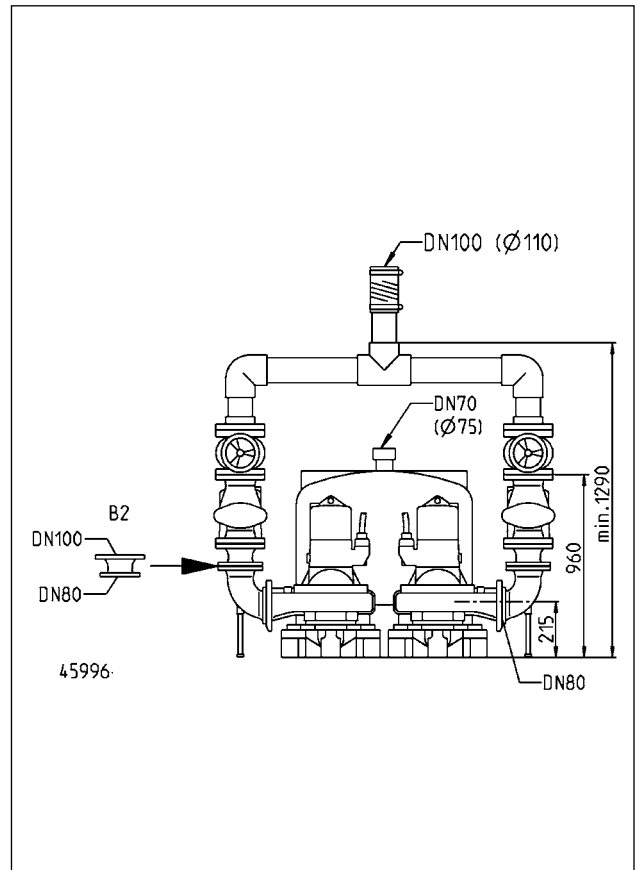
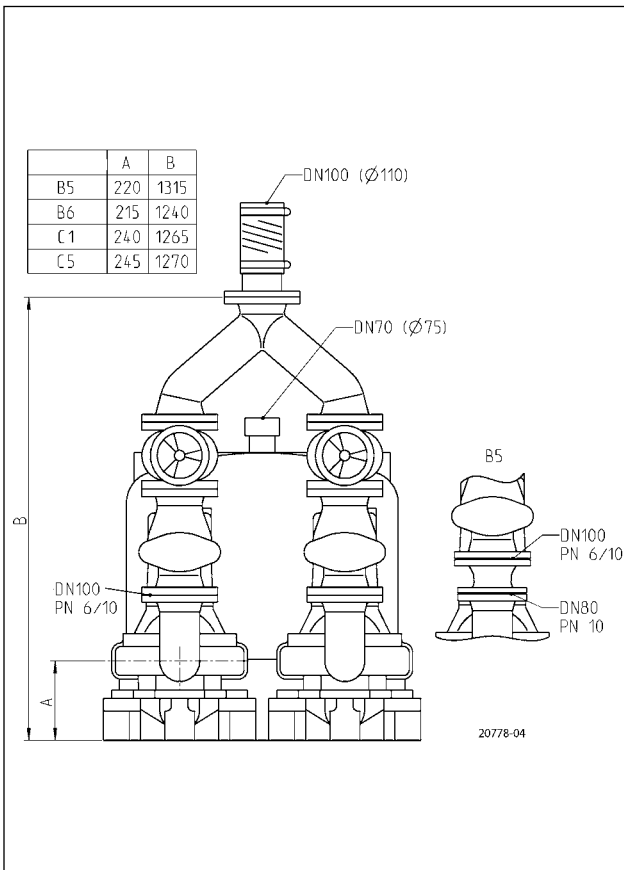
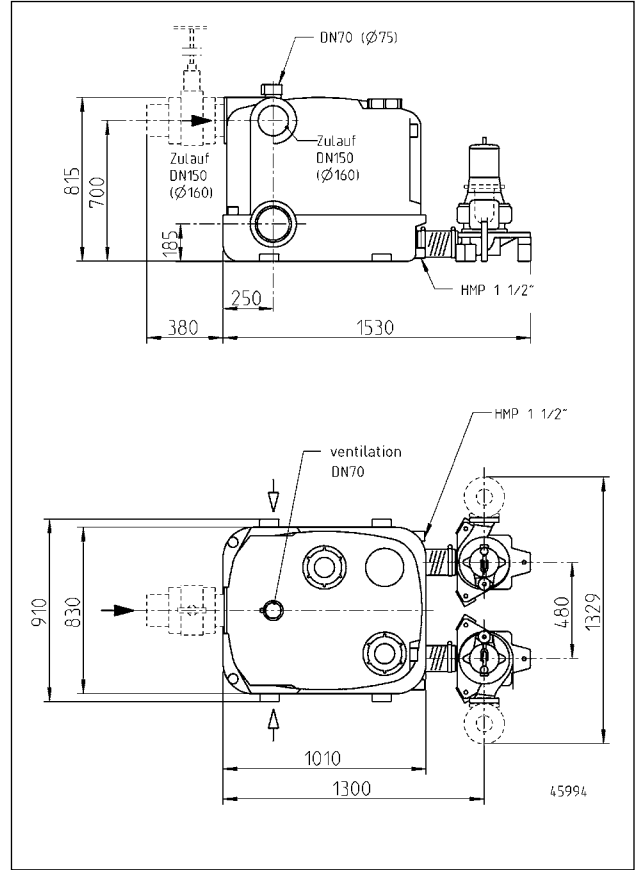
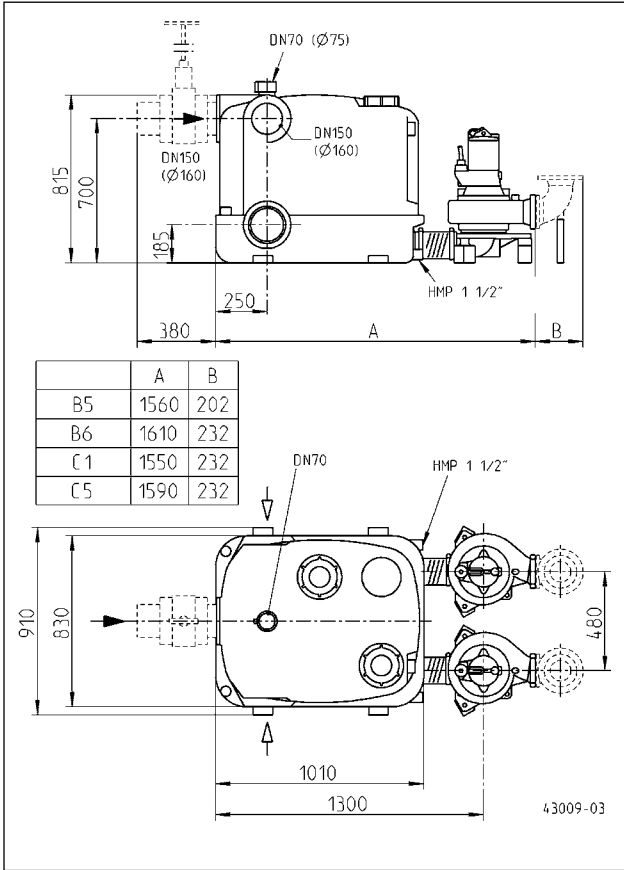

**Compli 2500**

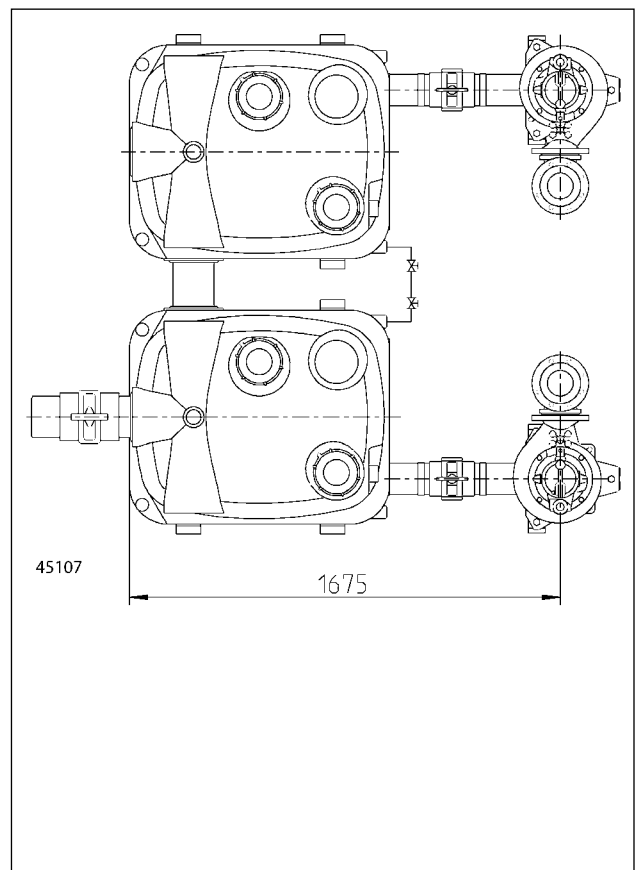
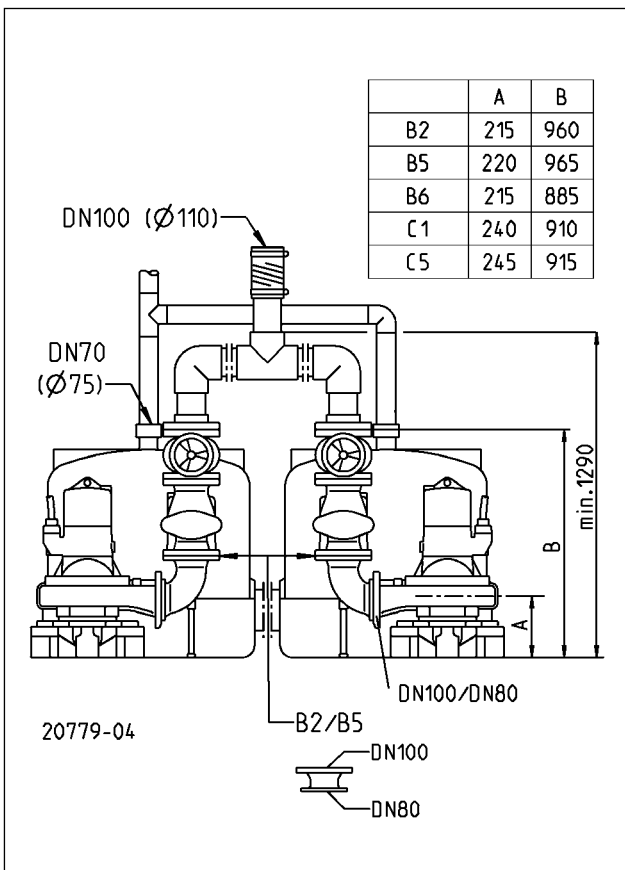
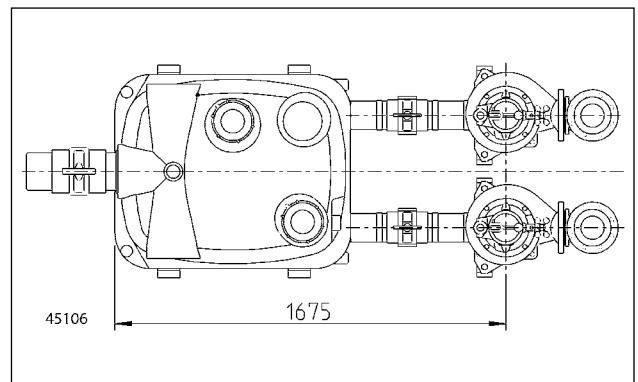
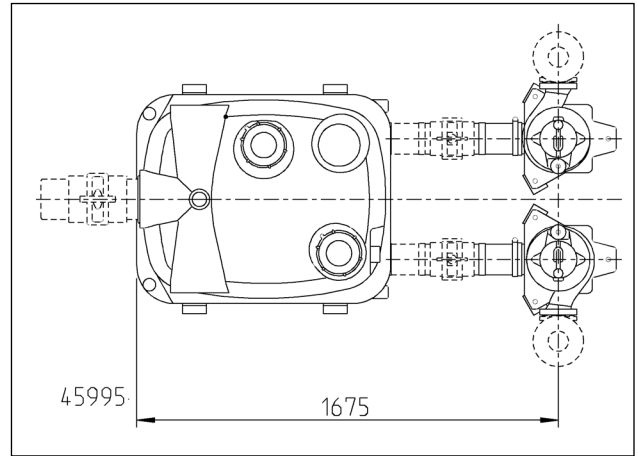
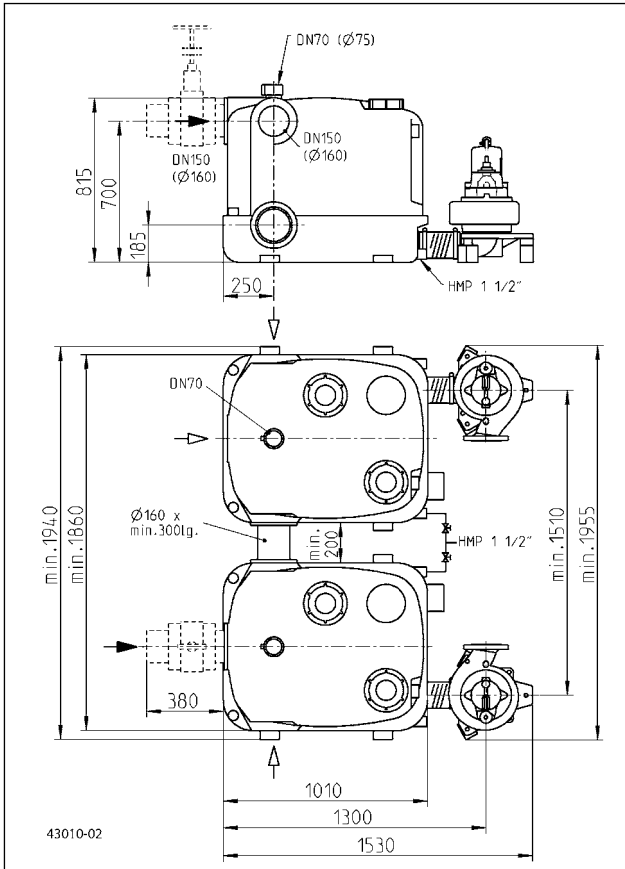



Compli Sensor

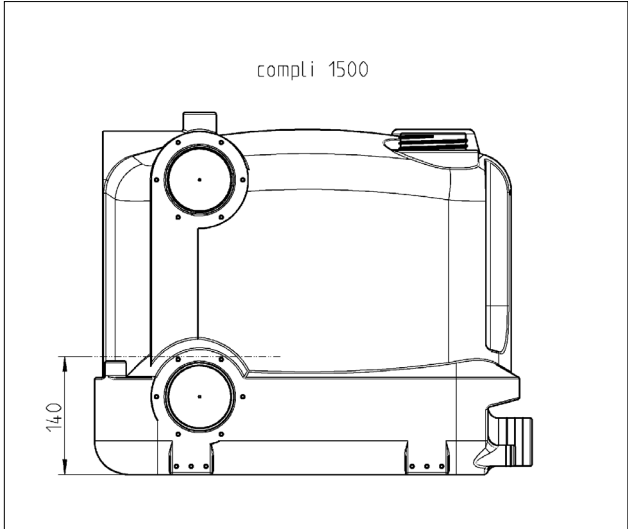

1	2	3	4	5	6	7	8	9	10	11	12	13	14	15	16	17	18	19	20	21	22	23	24
---	---	---	---	---	---	---	---	---	----	----	----	----	----	----	----	----	----	----	----	----	----	----	----

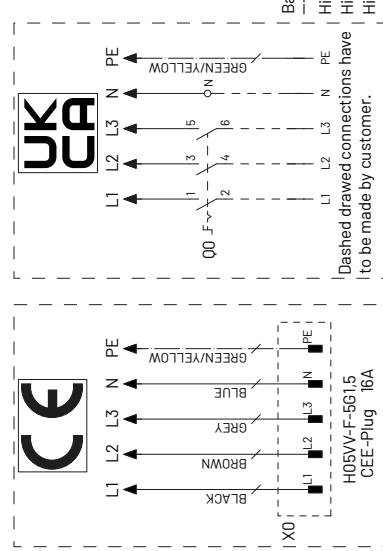
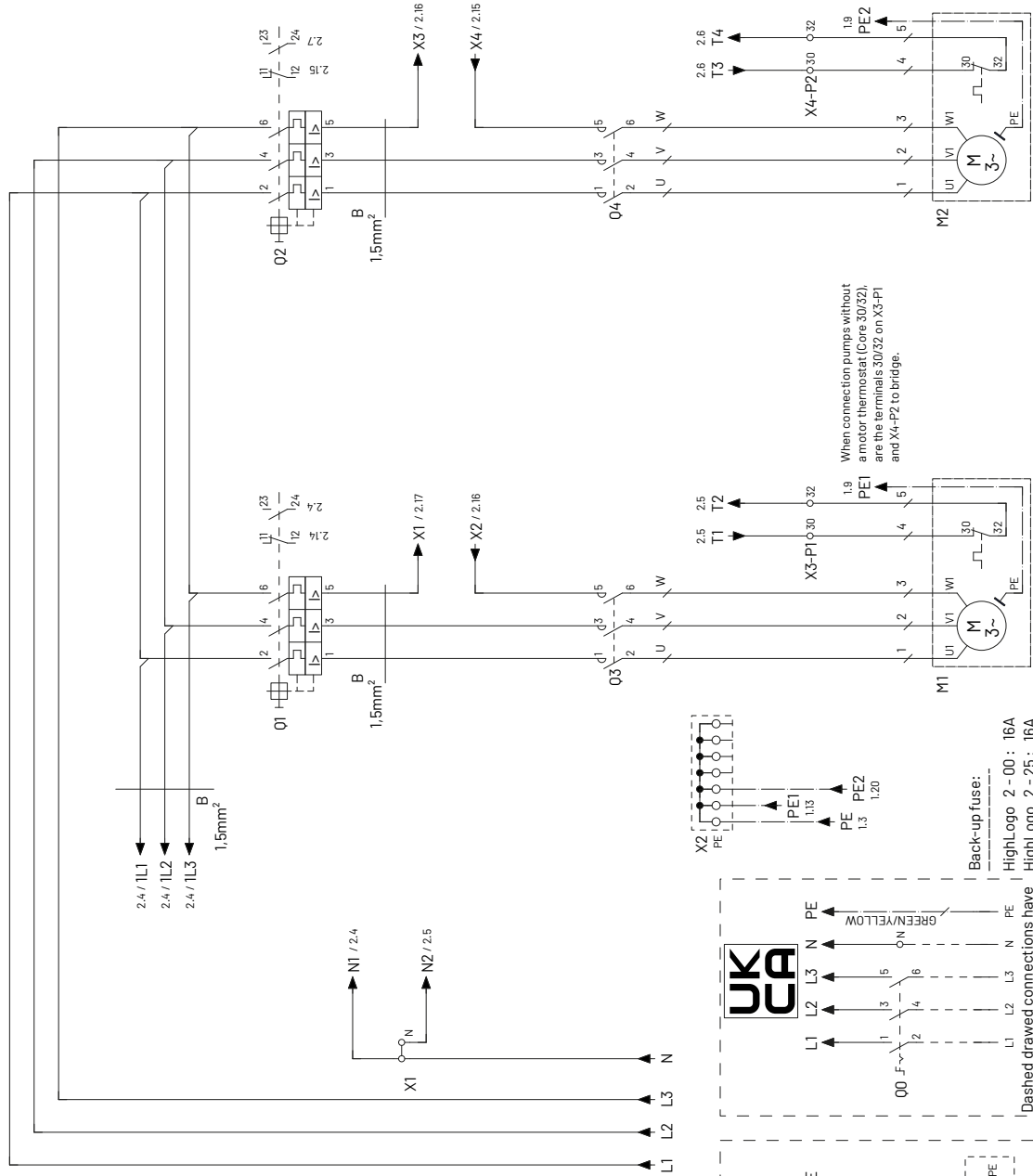

When connection pumps without a motor thermostat (Core 30/32), are the terminals 30/32 on X3-P1 and X4-P2 to bridge.



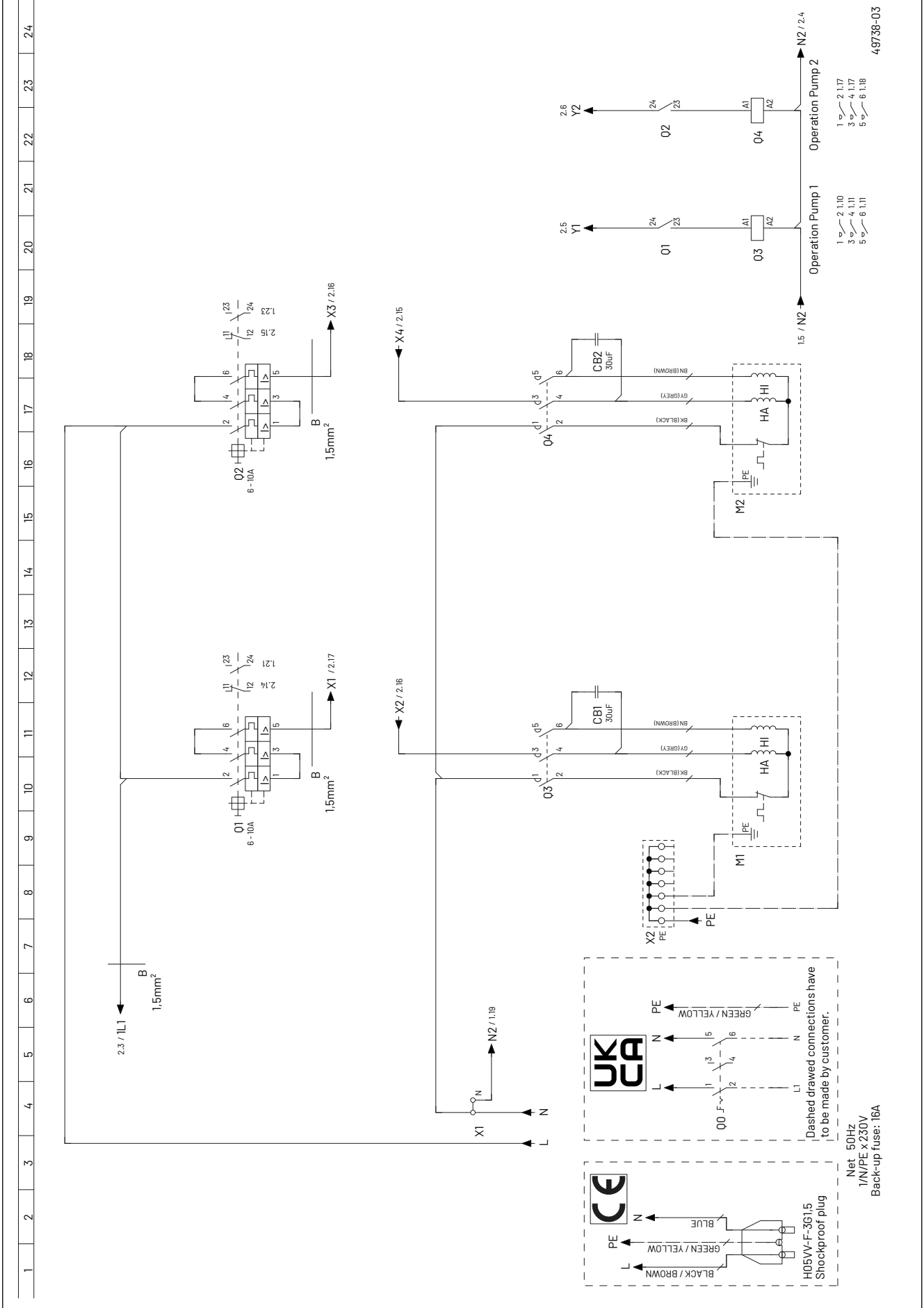

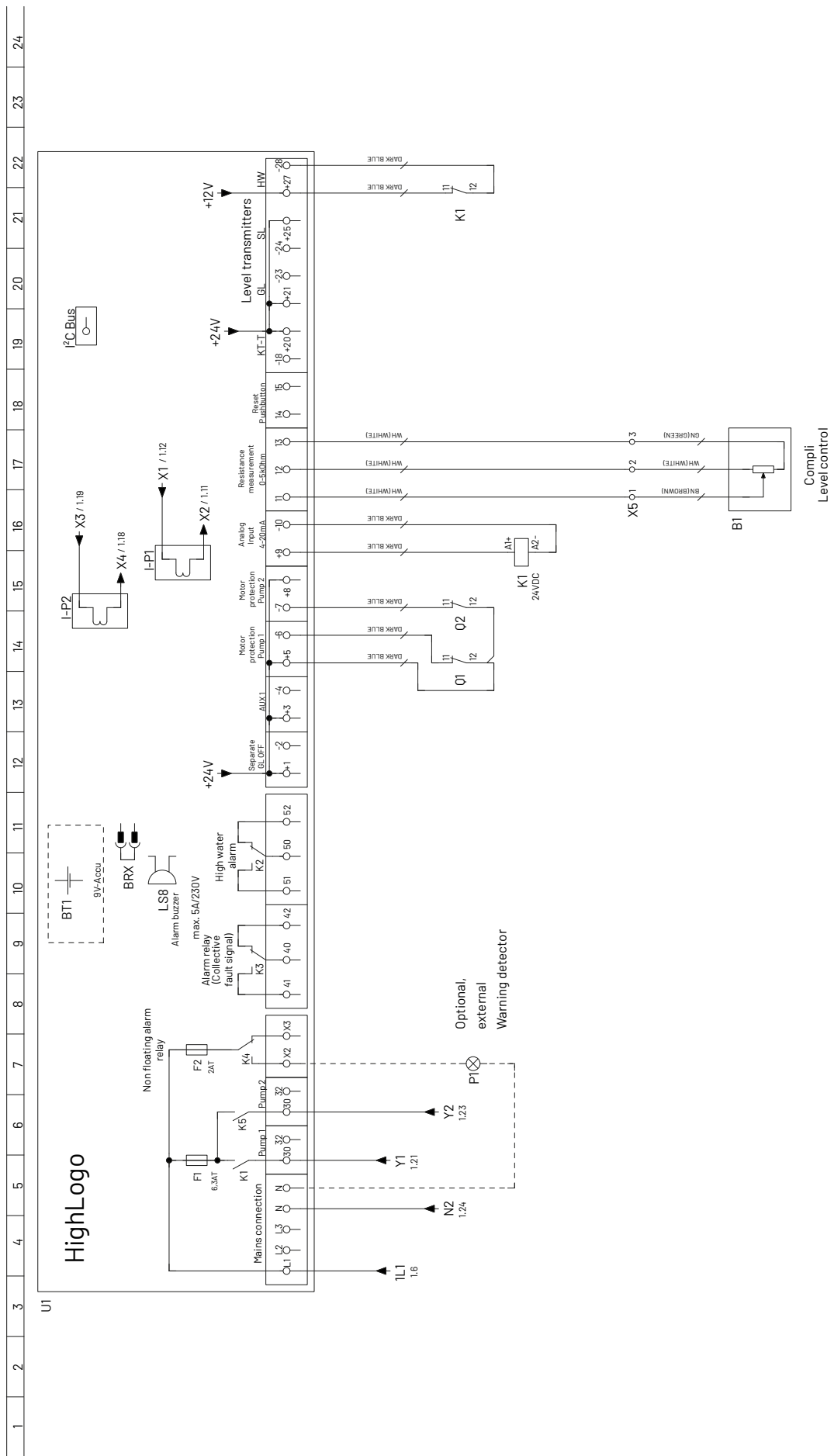

49736-03

11 12 2.22

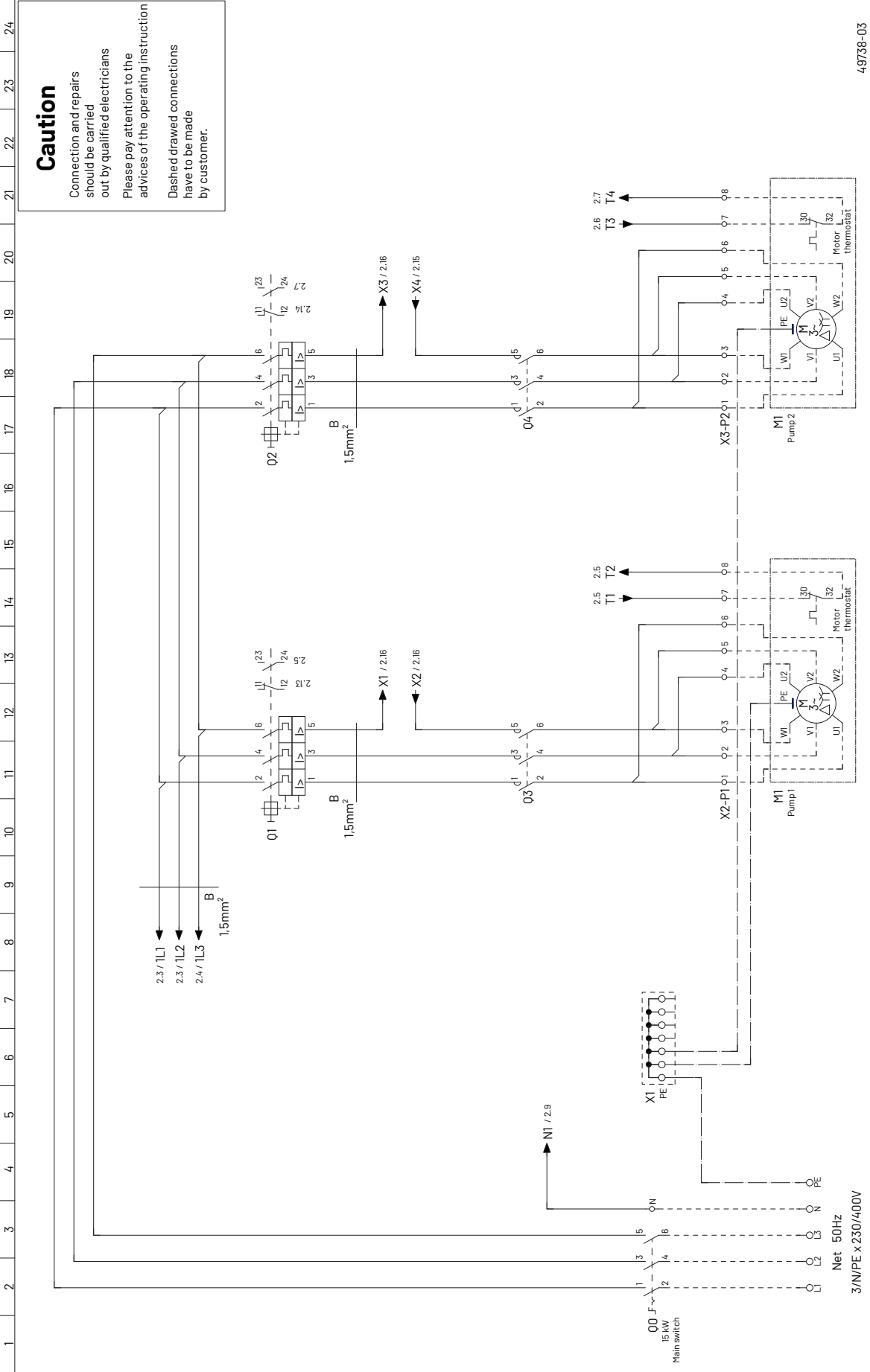

**Caution**  
 Connection and repairs should be carried out by qualified electricians. Please pay attention to the advices of the operating instruction by customer.  
 Dashed drawn connections have to be made by customer.

49738-03

Net: 50Hz  
 3/N/PE x 230/400V  
 Back-up fuse: 25A

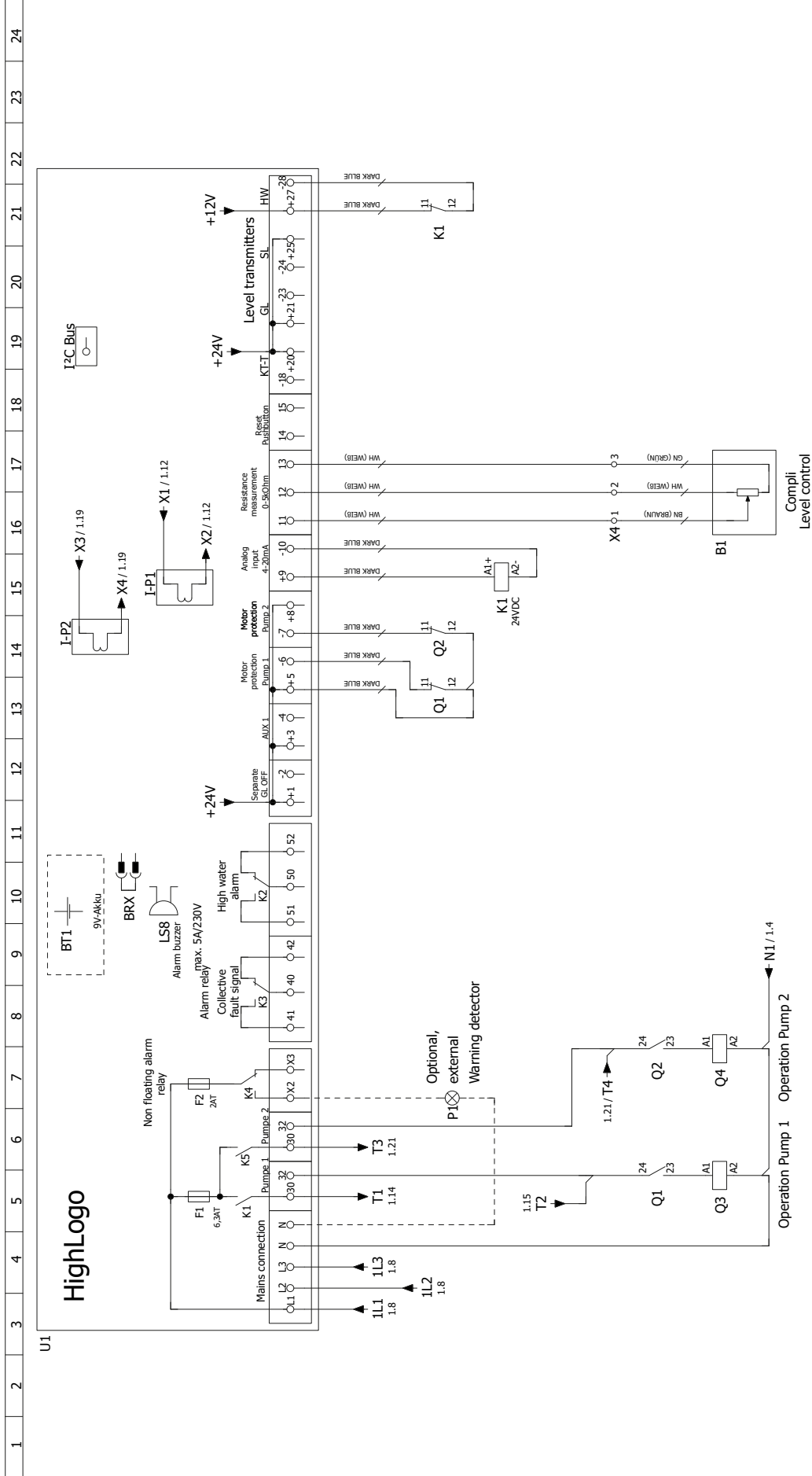

49738-03

11 12.2.21

1 2 1.11 2 1.18  
3 4 1.11 4 1.18  
5 6 1.12 6 1.18

1 2 1.11 2 1.18  
3 4 1.11 4 1.18  
5 6 1.12 6 1.18

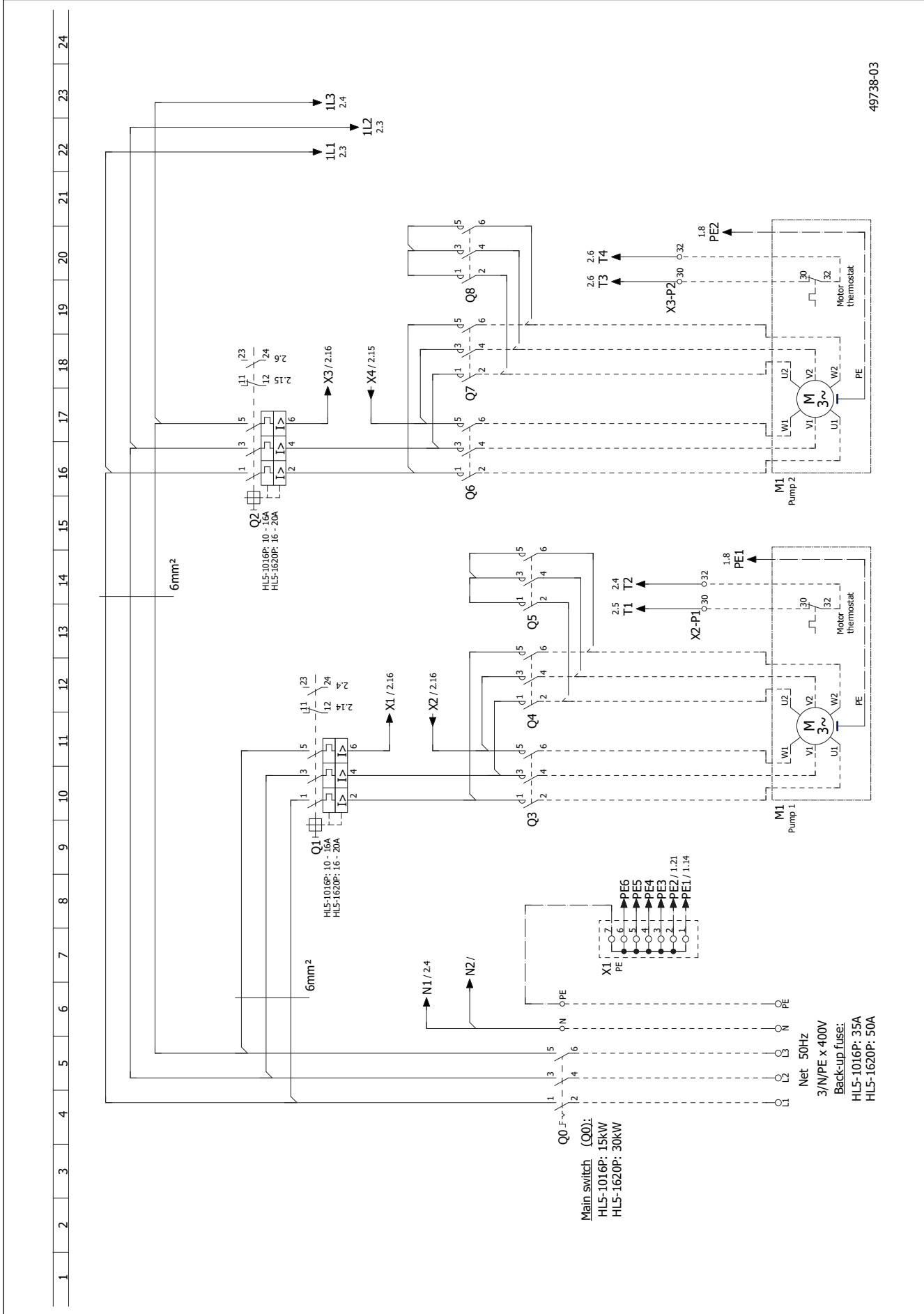

49738-03



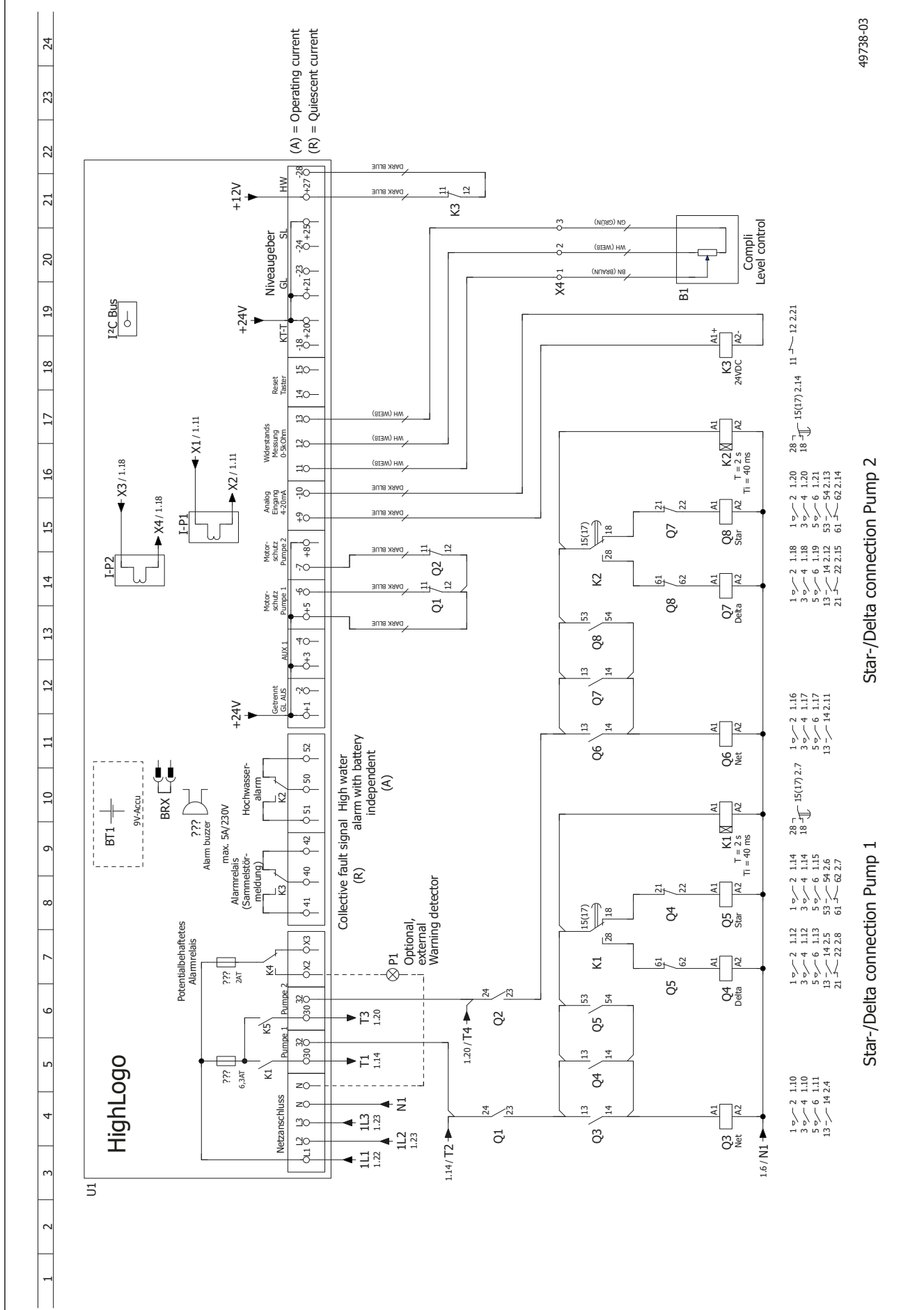

49738-03

Star-/Delta connection Pump 2

Star-/Delta connection Pump 1

1 2 3 4 5 6 7 8 9 10 11 12 13 14 15 16 17 18 19 20 21 22 23 24

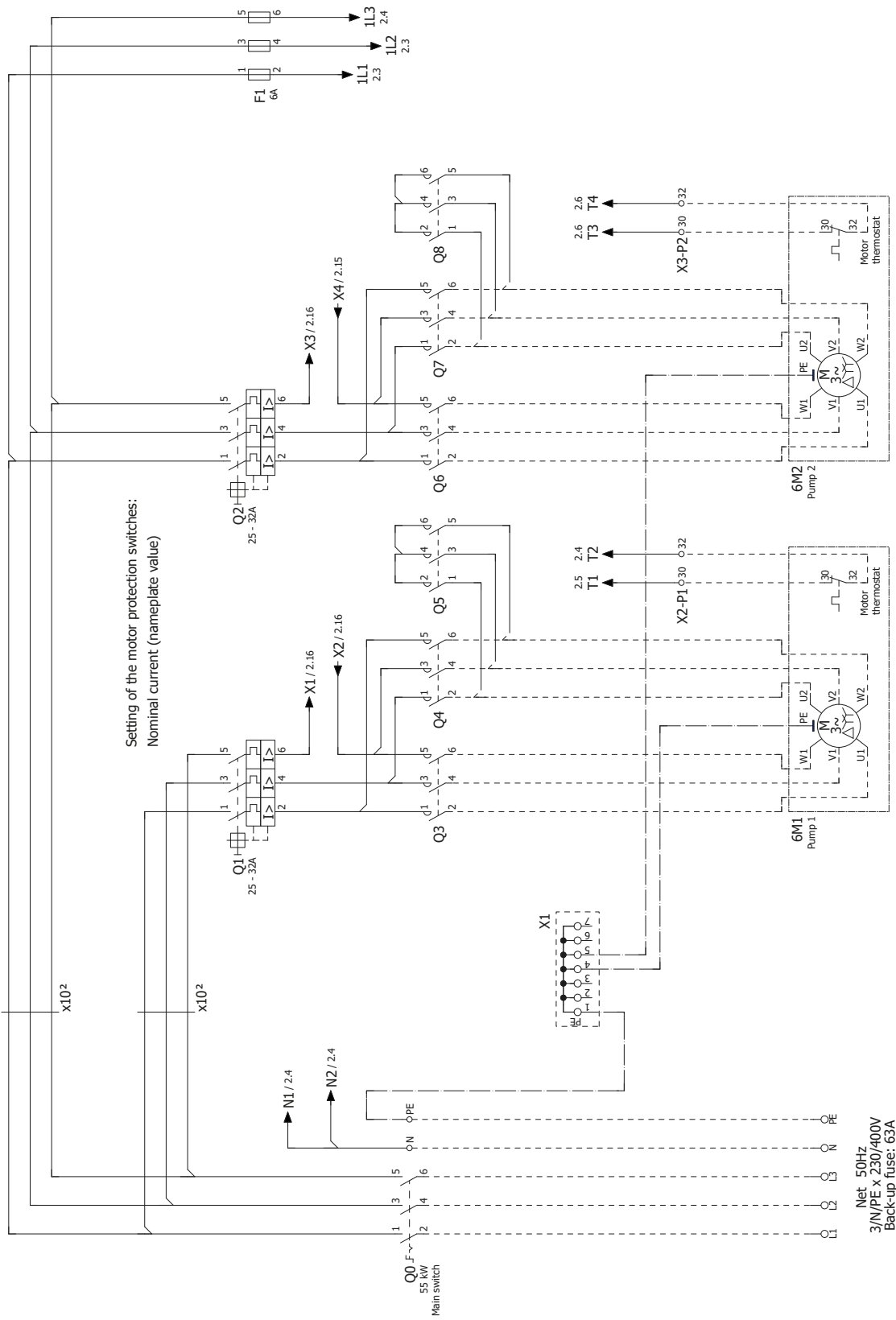

Setting of the motor protection switches:  
Nominal current (nameplate value)

Net: 50Hz  
3/N/PE x 230/400V  
Back-up fuse: 6SA

1 2 3 4 5 6 7 8 9 10 11 12 13 14 15 16 17 18 19 20 21 22 23 24

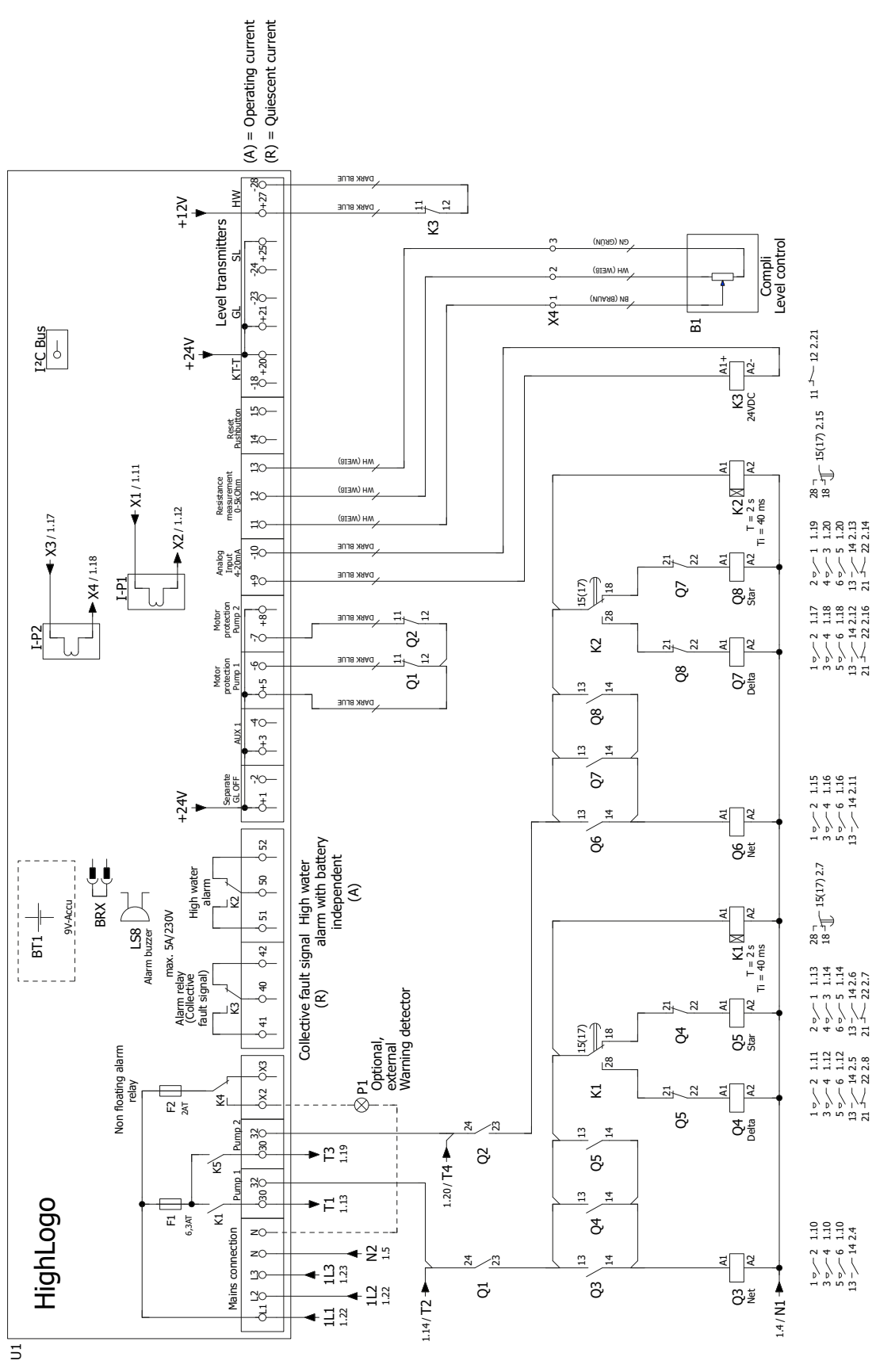

Star-/Delta connection Pump 1

Star-/Delta connection Pump 2

49738-03

EU-Konformitätserklärung  
EU-Prohlášení o shodě  
EU-Overensstemmelseserklæring  
EU-Declaration of Conformity  
EU-Vaatumustenmukaisuusvakuutus

EU-Déclaration de Conformité  
EU-Megfelelőségi nyilatkozat  
EU-Dichiarazione di conformità  
EU-Conformiteitsverklaring  
EU-Deklaracja zgodności

EU-Declaração de Conformidade  
EU-Declarație de conformitate  
EU-Vyhlášení o zhode  
EU-Försäkran om överensstämmelse

DE - Richtlinien - Harmonisierte Normen  
CS - Směrnice - Harmonizované normy  
DA - Direktiv - Harmoniseret standard  
EN - Directives - Harmonised standards  
FI - Direktiivi - Yhdenmukaistettu standardi

FR - Directives - Normes harmonisées  
HU - Irányelve - Harmonizált szabványok  
IT - Direttive - Norme armonizzate  
NL - Richtlijnen - Geharmoniseerde normen  
PL - Dyrektywy - Normy zharmonizowane

PT - Directiva - Normas harmonizadas  
RO - Directivă - Norme coroborate  
SK - Smernice - Harmonizované normy  
SV - Direktiv - Harmoniserade normer

- 2006/42/EG (MD) EN 809:1998/AC:2010, EN ISO 12100:2010, EN 60335-1:2012/A13:2017
- 2011/65/EU (RoHS)
- 2014/30/EU (EMC) EN 55014-1:2017/A11:2020, EN 55014-2:1997/A2:2008, EN 61000-3-2:2014, EN 61000-3-3:2013
- 2014/34/EU (ATEX) EN 1127-1:2019

JUNG PUMPEN GmbH - Industriestr. 4-6 - 33803 Steinhagen - Germany - www.jung-pumpen.de

DE - Wir erklären in alleiniger Verantwortung, dass das Produkt den aufgeführten Richtlinien entspricht.  
CS - Prohlašujeme na svou výlučnou odpovědnost, že výrobek odpovídá jmenovaným směrnici.  
DA - Vi erklærer under ansvar at produktet i overensstemmelse med de retningslinjer  
EN - We hereby declare, under our sole responsibility, that the product is in accordance with the specified Directives.  
FI - Me vakuutamme omalla vastuullamme, että tuote täyttää ohjeita.  
FR - Nous déclarons sous notre propre responsabilité que le produit répond aux directives.  
HU - Kizárólagos felelősségünk tudatában kijelentjük, hogy ez a termék megfelel az Európai Unió fentnevezett irányelveinek.  
IT - Noi dichiariamo sotto la nostra esclusiva responsabilità che il prodotto è conforme alle direttive citate  
NL - Wij verklaren geheel onder eigen verantwoordelijkheid dat het product voldoet aan de gestelde richtlijnen.  
PL - Z pełną odpowiedzialnością oświadczamy, że produkt odpowiada postanowieniom wymienionych dyrektyw.  
PT - Declaramos, sob nossa exclusiva responsabilidade, que o produto está em conformidade com as Diretivas especificadas.  
RO - Declaram pe proprie răspundere că produsul corespunde normelor prevăzute de directivele mai sus menționate.  
SK - Na výlučnú zodpovednosť vyhlasujeme, že výrobok spĺňa požiadavky uvedených smerníc.  
SV - Vi försäkrar att produkten på vårt ansvar är utförd enligt gällande riktlinjer.

compli 1010/4 BWE HL (JP50105)  
compli 1010/4 BW HL (JP50106)  
compli 1015/4 BW HL (JP50107)  
compli 1025/4 BW HL (JP50108)  
compli 1025/2 BW HL (JP50109)  
compli 1035/2 BW HL (JP50110)

compli 1210/4 BW HL (JP50118)  
compli 1215/4 BW HL (JP50119)  
compli 1225/4 BW HL (JP50120)  
compli 1225/2 BW HL (JP50121)  
compli 1235/2 BW HL (JP50122)

compli 1525/4 C1 HL (JP50123)  
compli 1535/4 C1 HL (JP50124)  
compli 1555/4 C5 HL (JP50125)  
compli 1575/4 C5 HL (JP50126)  
compli 1575/4 B6 HL (JP50127)  
compli 1535/2 B2 HL (JP50128)  
compli 1555/2 B2 HL (JP50129)  
compli 1575/2 B5 HL (JP50130)  
compli 15100/2 B5 HL (JP50131)  
compli 15200/2 B6 HL (JP50132)

compli 2525/4 C1 HL (JP50133)  
compli 2535/4 C1 HL (JP50134)  
compli 2555/4 C5 HL (JP50135)  
compli 2575/4 C5 HL (JP50136)  
compli 2575/4 B6 HL (JP50137)  
compli 2535/2 B2 HL (JP50138)  
compli 2555/2 B2 HL (JP50139)  
compli 2575/2 B5 HL (JP50140)  
compli 25100/2 B5 HL (JP50141)  
compli 25200/2 B6 HL (JP50142)

DE-Weitere normative Dokumente CS-Jinými normativními dokumenty DA-Andre normative dokumenter EN-Other normative documents FI-Muiden normien FR-Autres documents normatifs HU-Egyéb szabályozó dokumentumokban leírtaknak IT-Altri documenti normativi NL-Verdere normatieve documenten PL-Innymi dokumentami normatywnymi PT-Outros documentos normativos RO-Alte acte normative SK-Iným závazným dokumentom SV-Vidare normerande dokument:

EN 60335-2-41:2003/A2:2010,  
TRGS 727

DE-Bevollmächtigter für technische Dokumentation CS-Oprávněná osoba pro technickou dokumentaci DA-utoriseret person for teknisk dokumentation EN-Authorized person for technical documentation FI-Valtuutettu henkilö tekninen dokumentaatio FR-Personne autorisée à la documentation technique HU-Hivatalos személy műszaki dokumentáció IT-Persona abilitata per la documentazione tecnica NL-Bevoegd persoon voor technische documentatie PL-Petnomocnik ds. dokumentacji technicznej PT-Pessoa autorizada para documentação técnica RO-Persoană autorizată pentru documentație tehnică SK-Oprávněná osoba pre technickú dokumentáciu SV-Auktoriserad person för teknisk dokumentation:

JUNG PUMPEN - Stefan Sirges - Industriestr. 4-6 - 33803 Steinhagen

Steinhagen, 12-04-2022

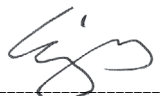
  
Stefan Sirges, General Manager

i.V.   
Pascal Kölkebeck, Sales Manager



## UKCA-Declaration of Conformity

---

Legislation - Designated Standards

- **Supply of Machinery (Safety) Regulations 2008 (MD)** EN 809:1998/AC:2010, EN ISO 12100:2010, EN 60335-1:2012/A13:2017
- **The Restriction of the Use of Certain Hazardous Substance in Electrical and Electronic Equipment Regulations 2012 (RoHS)**
- **Electromagnetic Compatibility Regulations 2016 (EMC)** EN55014-1:2017/A11:2020, EN 55014-2:1997/A2:2008, EN 60034-1: 2010/AC: 2010, EN 61000-3-2:2014, EN 61000-3-3:2013

Name and address of the manufacturer: JUNG PUMPEN GmbH - Industriestr. 4-6 - 33803 Steinhagen - Germany - www.jung-pumpen.de

We hereby declare, under our sole responsibility, that the product is in accordance with the specified Legislation.

Compli 1215/4 HL GB 15M (JP50165)  
Compli 1225/4 HL GB 15M (JP50166)  
Compli 1210/4 HL GB 15M (JP50737)  
Compli 1210/4 E HL GB 15M (JP50169)  
Compli 1210/4 E HL GB (JP50170)  
Compli 1215/4 BW HL (JP50736)  
Compli 1225/4 BW HL (JP50738)  
Compli 1225/2 BW HL (JP50739)  
Compli 1235/2 BW HL (JP50740)

Compli 1525/4 C1 HL (JP50741)  
Compli 1535/4 C1 HL (JP50742)  
Compli 1555/4 C5 HL (JP50743)  
Compli 1575/4 C5 HL (JP50744)  
Compli 1575/4 B6 HL (JP50745)  
Compli 1535/2 B2 HL (JP50746)  
Compli 1555/2 B2 HL (JP50747)  
Compli 1555/2 B2 HL (JP50748)

Compli 15100/2 B5 HL (JP50749)  
Compli 15200/2 B6 HL (JP50750)  
Compli 2525/4 C1 HL (JP50751)  
Compli 2535/4 C1 HL (JP50752)  
Compli 2555/4 C5 HL (JP50753)  
Compli 2575/4 C5 HL (JP50754)  
Compli 2575/4 B6 HL (JP50755)  
Compli 2535/2 B2 HL (JP50756)  
Compli 2555/2 B2 HL (JP50757)  
Compli 2575/2 B5 HL (JP50758)  
Compli 25100/2 B5 HL (JP50759)  
Compli 25200/2 B6 HL (JP50760)

Other normative documents:

EN 60335-2-41:2003/A2:2010

Authorized person for technical documentation

JUNG PUMPEN - Stefan Sirges - Industriestr. 4-6 - 33804 Steinhagen

Steinhagen, 20-10-2022



Stefan Sirges, General Manager



i.V. Pascal Kölkebeck, Sales Manager

 0197	
JUNG PUMPEN GmbH - Industriestr. 4-6 33803 Steinhagen, Germany 20 466.11.2021.10	
<b>EN 12050-1:2001; 2015</b> <b>Fäkalienhebeanlage</b>	
<p>Compli 1525/4 C1 HL (JP50123)            Compli 1535/4 C1 HL (JP50124)            Compli 1555/4 C5 HL (JP50125)            Compli 1575/4 C5 HL (JP50126)            Compli 1575/4 B6 HL (JP50127)            Compli 1535/2 B2 HL (JP50128)            Compli 1555/2 B2 HL (JP50129)            Compli 1575/2 B5 HL (JP50130)            Compli 15100/2 B5 HL (JP50131)            Compli 15200/2 B6 HL (JP50132)</p> <p>Compli 2525/4 C1 HL (JP50133)            Compli 2535/4 C1 HL (JP50134)            Compli 2555/4 C5 HL (JP50135)            Compli 2575/4 C5 HL (JP50136)            Compli 2575/4 B6 HL (JP50137)            Compli 2535/2 B2 HL (JP50138)            Compli 2555/2 B2 HL (JP50139)            Compli 2575/2 B5 HL (JP50140)            Compli 25100/2 B5 HL (JP50141)            Compli 25200/2 B6 HL (JP50142)</p>	
Sammeln und automatisches Heben von fäkalienfreiem und fäkalienhaltigem Abwasser über die Rückstauenebene	

BRANDVERHALTEN	NPD
WASSERDICHTHEIT, LUFTDICHTHEIT	
- Wasserdichtheit	Bestanden
- Geruchsdichtheit	Bestanden
WIRKSAMKEIT (HEBEWIRKUNG)	
- Förderung von Feststoffen	Bestanden
- Rohranschlüsse	Bestanden
- Mindestmaße von Lüftungsleitungen	Bestanden
- Mindestfließgeschwindigkeit	Bestanden
- Freier Minstdurchgang der Anlage	Bestanden
- Mindestnutzvolumen	Bestanden
MECHANISCHE FESTIGKEIT	
- Tragfähigkeit und strukturelle Stabilität des Sammelbehälters für die Verwendung außerhalb von Gebäuden	NPD
- Strukturelle Stabilität des Sammelbehälters für die Verwendung innerhalb von Gebäuden	Bestanden
GERÄUSCHPEGEL	70 dB(A)
DAUERHAFTIGKEIT	
- der Wasserdichtheit und Luftdichtheit	Bestanden
- der Hebewirkung	Bestanden
- der mechanischen Festigkeit	Bestanden
GEFÄHRLICHE SUBSTANZEN	NPD

 0197	
JUNG PUMPEN GmbH - Industriestr. 4-6 33803 Steinhagen, Germany 20 466.11.2021.10	
<b>EN 12050-1:2001; 2015</b> <b>Lifting plant for wastewater containing faecal matter</b>	
<p>Compli 1525/4 C1 HL (JP50741)            Compli 1535/4 C1 HL (JP50742)            Compli 1555/4 C5 HL (JP50743)            Compli 1575/4 C5 HL (JP50744)            Compli 1575/4 B6 HL (JP50745)            Compli 1535/2 B2 HL (JP50746)            Compli 1555/2 B2 HL (JP50747)            Compli 1575/2 B2 HL (JP50748)            Compli 15100/2 B5 HL (JP50749)            Compli 15200/2 B6 HL (JP50750)</p> <p>Compli 2525/4 C1 HL (JP50751)            Compli 2535/4 C1 HL (JP50752)            Compli 2555/4 C5 HL (JP50753)            Compli 2575/4 C5 HL (JP50754)            Compli 2575/4 B6 HL (JP50755)            Compli 2535/2 B2 HL (JP50756)            Compli 2555/2 B2 HL (JP50757)            Compli 2575/2 B5 HL (JP50758)            Compli 25100/2 B5 HL (JP50759)            Compli 25200/2 B6 HL (JP50760)</p>	
Collection and automatic lifting of wastewater without sewage and wastewater containing faecal matters above the backflow level	

REACTION TO FIRE	NPD
WATERTIGHTNESS, AIRTIGHTNESS	
- Water tightness	Pass
- Odour tightness	Pass
EFFECTIVENESS (LIFTING EFFECTIVENESS)	
- Pumping of solids	Pass
- Pipe connections	Pass
- Minimum dimensions of ventilating pipes system	Pass
- Minimum flow velocity	Pass
- Minimum free passage of the plant	Pass
- Minimum useful volume	Pass
MECHANICAL RESISTANCE	
- Load bearing capacity and structural stability of collection tank for use outside buildings	NPD
- Structural stability of collection tank for use inside buildings	Pass
NOISE LEVEL	70 dB(A)
DURABILITY	
- of structural stability	Pass
- of lifting effectiveness	Pass
- of mechanical resistance	Pass
DANGEROUS SUBSTANCES	NPD

 0197
JUNG PUMPEN GmbH - Industriestr. 4-6 33803 Steinhagen, Germany 20 466.11.2021.10
<b>EN 12050-1:2001; 2015</b> <b>Station de relevage pour effluents contenant des matières fécales</b>
<p>           Compli 1525/4 C1 HL (JP50123)            Compli 1535/4 C1 HL (JP50124)            Compli 1555/4 C5 HL (JP50125)            Compli 1575/4 C5 HL (JP50126)            Compli 1575/4 B6 HL (JP50127)            Compli 1535/2 B2 HL (JP50128)            Compli 1555/2 B2 HL (JP50129)            Compli 1575/2 B5 HL (JP50130)            Compli 15100/2 B5 HL (JP50131)            Compli 15200/2 B6 HL (JP50132)         </p> <p>           Compli 2525/4 C1 HL (JP50133)            Compli 2535/4 C1 HL (JP50134)            Compli 2555/4 C5 HL (JP50135)            Compli 2575/4 C5 HL (JP50136)            Compli 2575/4 B6 HL (JP50137)            Compli 2535/2 B2 HL (JP50138)            Compli 2555/2 B2 HL (JP50139)            Compli 2575/2 B5 HL (JP50140)            Compli 25100/2 B5 HL (JP50141)            Compli 25200/2 B6 HL (JP50142)         </p>
Collecte et relevage automatique des eaux usées exemptes de matières fécales et des eaux usées contenant des matières fécales au-dessus du niveau de refoulement.

RÉACTION AU FEU	NPD
ÉTANCHÉITÉ À L'EAU, ÉTANCHÉITÉ À L'AIR - Étanchéité à l'eau - Étanchéité aux odeurs	satisfaisant satisfaisant
EFFICACITÉ (PERFORMANCE DE RELEVAGE) - Refoulement de matières solides - Raccords de tuyaux - Dimensions minimales des conduites d'aération - Débit minimum - Passage libre minimal de l'installation - Volume utile minimal	satisfaisant satisfaisant satisfaisant satisfaisant satisfaisant satisfaisant
RÉSISTANCE MÉCANIQUE - Capacité de charge et stabilité structurelle du collecteur pour une utilisation à l'extérieur des bâtiments - Stabilité structurelle du collecteur pour une utilisation à l'intérieur des bâtiments	NPD satisfaisant
NIVEAU SONORE	70 dB(A)
RÉSISTANCE - de la stabilité structurelle - de la performance de relevage - de la résistance mécanique	satisfaisant satisfaisant satisfaisant
SUBSTANCES DANGEREUSES	NPD

 0197
JUNG PUMPEN GmbH - Industriestr. 4-6 33803 Steinhagen, Germany 20 466.11.2021.10
<b>EN 12050-1:2001; 2015</b> <b>Fecaliënpompinstallatie</b>
<p>           Compli 1525/4 C1 HL (JP50123)            Compli 1535/4 C1 HL (JP50124)            Compli 1555/4 C5 HL (JP50125)            Compli 1575/4 C5 HL (JP50126)            Compli 1575/4 B6 HL (JP50127)            Compli 1535/2 B2 HL (JP50128)            Compli 1555/2 B2 HL (JP50129)            Compli 1575/2 B5 HL (JP50130)            Compli 15100/2 B5 HL (JP50131)            Compli 15200/2 B6 HL (JP50132)         </p> <p>           Compli 2525/4 C1 HL (JP50133)            Compli 2535/4 C1 HL (JP50134)            Compli 2555/4 C5 HL (JP50135)            Compli 2575/4 C5 HL (JP50136)            Compli 2575/4 B6 HL (JP50137)            Compli 2535/2 B2 HL (JP50138)            Compli 2555/2 B2 HL (JP50139)            Compli 2575/2 B5 HL (JP50140)            Compli 25100/2 B5 HL (JP50141)            Compli 25200/2 B6 HL (JP50142)         </p>
Verzamelen en automatisch pompen van afvalwater zonder fecaliën en afvalwater met fecaliën boven het terugstuwniveau

BRANDGEDRAG	NPD
WATERDICHTHEID, LUCHTDICHTHEID - Waterdichtheid - Geurdichtheid	succesvol succesvol
RENDEMENT (POMPWERKING) - Transport van vaste stoffen - Buisaansluitingen - Minimum afmeting van verluchttingsleidingen - Minimum doorstromingssnelheid - Minimum vrije doorgang van de installatie - Minimum nuttig volume	succesvol succesvol succesvol succesvol succesvol succesvol
MECHANISCHE VASTHEID - Draagkracht en structurele stabiliteit van de verzamelcontainer voor het gebruik buiten gebouwen - Structurele stabiliteit van de verzamelcontainer voor het gebruik binnenin gebouwen	NPD succesvol
GELUIDSNIVEAU	70 dB(A)
DUURZAAMHEID - van de structurele stabiliteit - van de pompwerking - van de mechanische vastheid	succesvol succesvol succesvol
GEVAARLIJKE STOFFEN	NPD

 0197
JUNG PUMPEN GmbH - Industriestr. 4-6 33803 Steinhagen, Germany 20 466.11.2021.10
<b>EN 12050-1:2001; 2015</b> <b>Stazione di sollevamento per acque reflue contenenti materiale fecale</b>
<p>Compli 1525/4 C1 HL (JP50123) Compli 1535/4 C1 HL (JP50124) Compli 1555/4 C5 HL (JP50125) Compli 1575/4 C5 HL (JP50126) Compli 1575/4 B6 HL (JP50127) Compli 1535/2 B2 HL (JP50128) Compli 1555/2 B2 HL (JP50129) Compli 1575/2 B5 HL (JP50130) Compli 15100/2 B5 HL (JP50131) Compli 15200/2 B6 HL (JP50132)</p> <p>Compli 2525/4 C1 HL (JP50133) Compli 2535/4 C1 HL (JP50134) Compli 2555/4 C5 HL (JP50135) Compli 2575/4 C5 HL (JP50136) Compli 2575/4 B6 HL (JP50137) Compli 2535/2 B2 HL (JP50138) Compli 2555/2 B2 HL (JP50139) Compli 2575/2 B5 HL (JP50140) Compli 25100/2 B5 HL (JP50141) Compli 25200/2 B6 HL (JP50142)</p>
Raccolta e sollevamento automatico di acque reflue prive di sostanze fecali e di acque reflue contenenti sostanze fecali al di sopra del livello di ristagno

INFIAMMABILITÀ	NPD
IMPERMEABILITÀ, ERMETICITÀ ALL'ARIA - Impermeabilità - Ermeticità agli odori	Superata Superata
EFFICACIA (CAPACITÀ DI SOLLEVAMENTO) - Pompaggio di materiali solidi - Collegamenti al tubo - Misure minime delle linee di ventilazione - Velocità di scorrimento minima - Passaggio libero minimo dell'impianto - Volume utile minimo	Superata Superata Superata Superata Superata Superata
RESISTENZA MECCANICA - Capacità di carico e stabilità strutturale del serbatoio di raccolta per l'uso al di fuori degli edifici - Stabilità strutturale del serbatoio di raccolta per l'uso all'interno degli edifici.	NPD Superata
SOGLIA DI RUMOROSITÀ	70 dB(A)
DUREVOLEZZA - della stabilità strutturale - della capacità di sollevamento - della resistenza meccanica	Superata Superata Superata
SOSTANZE PERICOLOSE	NPD

 0197
JUNG PUMPEN GmbH - Industriestr. 4-6 33803 Steinhagen, Germany 20 466.11.2021.10
<b>EN 12050-1:2001; 2015</b> <b>Instalacja przepompowni fekalii</b>
<p>Compli 1525/4 C1 HL (JP50123) Compli 1535/4 C1 HL (JP50124) Compli 1555/4 C5 HL (JP50125) Compli 1575/4 C5 HL (JP50126) Compli 1575/4 B6 HL (JP50127) Compli 1535/2 B2 HL (JP50128) Compli 1555/2 B2 HL (JP50129) Compli 1575/2 B5 HL (JP50130) Compli 15100/2 B5 HL (JP50131) Compli 15200/2 B6 HL (JP50132)</p> <p>Compli 2525/4 C1 HL (JP50133) Compli 2535/4 C1 HL (JP50134) Compli 2555/4 C5 HL (JP50135) Compli 2575/4 C5 HL (JP50136) Compli 2575/4 B6 HL (JP50137) Compli 2535/2 B2 HL (JP50138) Compli 2555/2 B2 HL (JP50139) Compli 2575/2 B5 HL (JP50140) Compli 25100/2 B5 HL (JP50141) Compli 25200/2 B6 HL (JP50142)</p>
Zbieranie i automatyczne przepompowywanie ścieków bez fekalii i ścieków fekalnych powyżej poziomu cofki

WŁAŚCIWOŚCI OGNIOWE	NPD
SZCZELNOŚĆ WODNA I POWIETRZNA - Szczelność wodna - Szczelność zapachowa	Pozytywnie Pozytywnie
SPRAWNOŚĆ DZIAŁANIA (SKUTECZNOŚĆ TŁOCZENIA) - Tłoczenie substancji stałych - Przyłącza rurowe - Wymiary minimalne przewodów wentylacyjnych - Minimalna prędkość przepływu - Minimalna, swobodna przepustowość instalacji - Minimalna objętość użytkowa	Pozytywnie Pozytywnie Pozytywnie Pozytywnie Pozytywnie Pozytywnie
WYTRZYMAŁOŚĆ MECHANICZNA - Nośność i stabilność konstrukcyjna zbiornika podczas stosowania poza budynkami - Nośność i stabilność konstrukcyjna zbiornika podczas stosowania w budynkach	NPD Pozytywnie
POZIOM HAŁASU	70 dB(A)
TRWAŁOŚĆ I WYTRZYMAŁOŚĆ - stabilność konstrukcyjna - skuteczność tłoczenia - wytrzymałość mechaniczna	Pozytywnie Pozytywnie Pozytywnie
SUBSTANCJE NIEBEZPIECZNE	NPD