

U3

DRAINAGE PUMPS

- Cooling jacket for motor housing
- Low level pumping by detachable strainer base
- Flushing device activatable and deactivatable
- Variable discharge branch with closable ventilation
- Safe to run dry
- EIP Technology
- Moisture sealed cable inlet
- Fluid temperature 35 °C, temporarily 60 °C (10 min.)



DESCRIPTION

The U3 K(S) are versatile submersible pumps for stationary and portable use. GID technology for more operational safety, an integrated flushing device to reduce deposits and the integrated low level pumping to remove flooding ensure many years of trouble-free operation.

The U3 K(S) pump rainwater, slightly polluted water or domestic wastewater (grey water), also from household dishwashers and washing machines (also high temperature).

In stationary use they remove the water from drains in cellars, laundries or storerooms and serve as a flood protection. Sliding guide rail systems offer the advantages of quick and easy maintenance. The Easyfix installation sets are particularly convenient. They are pre-assembled ready to plug in and can be installed as single or double systems.

The U3 K(S) can be combined with the above- and underfloor tanks of the Hebefix and Baufix series.

Should the sump or tank temporarily run dry, the pump is automatically vented via an opening in the discharge elbow.

The U3 K(S) must not be used for pumping wastewater containing faeces or wastewater from urinal systems

If submersible pumps are used outdoors, only a pump with 10 m cable without extension cable may be used in accordance with VDE Regulation 0100. For construction sites and garden ponds, a H07-type cable must be used.

PERFORMANCE

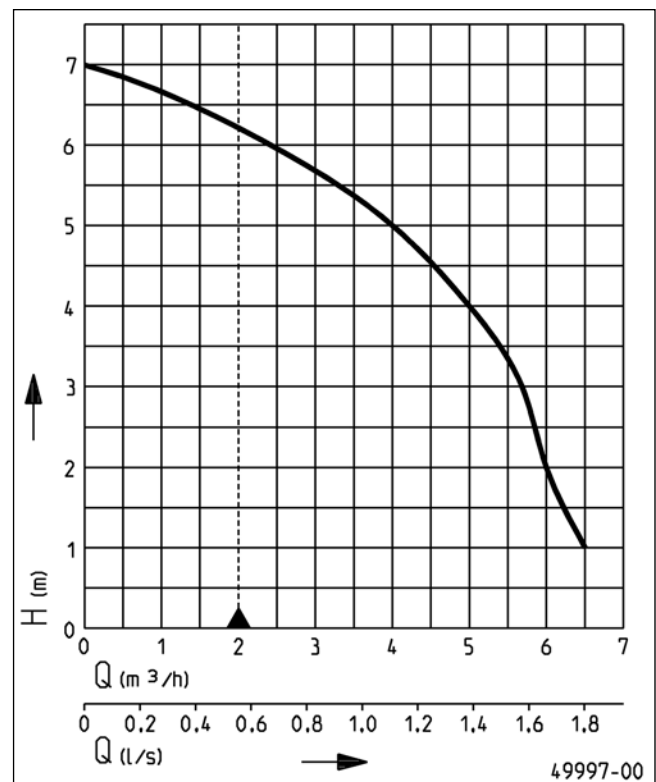

Type	Delivery head H [m]	1	2	3	4	5	6
U3K/U3KS	Flow rate Q [m³/h]	6.5	6.0	5.7	5.0	4.0	2.4

Specifications can be changed without notice. Performance subject to ISO 9906 tolerances. The minimum flow velocity in the pressure piping must be 0.7 m/s according to EN 12056. This data is represented in the performance curve as a limit of application.



SCOPE OF SUPPLY

Pump ready for connection acc. to EN 12050 with 90°, 1/4" female connection elbow with integrated self-ventilation, cable and plug, S model with automatic level float switch.

MECHANICAL DATA

Pump	Vertical single-stage	Run dry protection	Yes
Free passage	10 mm	Shaft	Stainless steel
Bearing	Ball bearings, grease-lubricated	Impeller	Vortex impeller, GFK
Seal on motor side	Rotary shaft seal	Motor housing	Stainless steel
Oil chamber	Yes	Pump housing	GRP
Seal on medium side	2-fold rotary shaft seals	Submersible	Yes
		Pressure outlet	1 1/4"

ELECTRICAL DATA

Voltage	1/N/PE~230 V	Insulation class	F
Motor rating P1	0.32 kW	Winding thermostat	Yes
Motor rating P2	0.2 kW	Motor protection	Integrated
Current	1.4 A	Plug	Safety
Type of enclosure	IP 68		

U3

Type	Code No.	Power line	Wires	Weight
Without level control				
U3K, 10 m cable	JP50002	10m H05RN-F	3G0,75	3.7 kg
With built-in level control				
U3KS, 4 m cable	JP50000	4m H05RN-F	3G0,75	3.4 kg
U3KS, 10 m cable	JP50001	10m H07RN-F	3G1,0	4.3 kg

Dimensions and switching points U3 KS (mm)

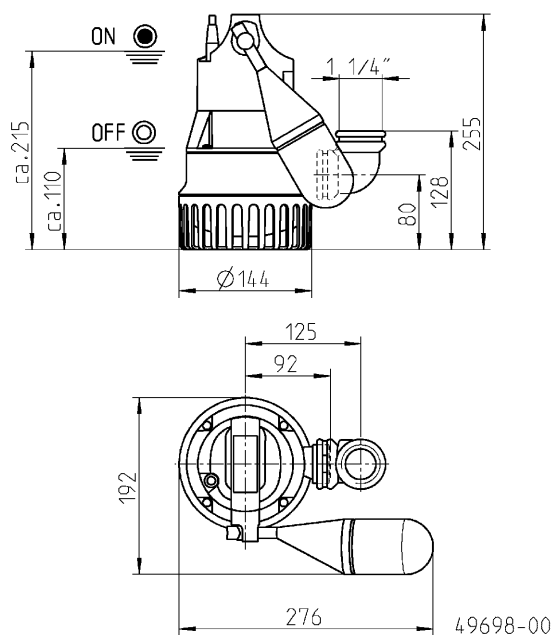

Dimensions and switching points special float (mm)

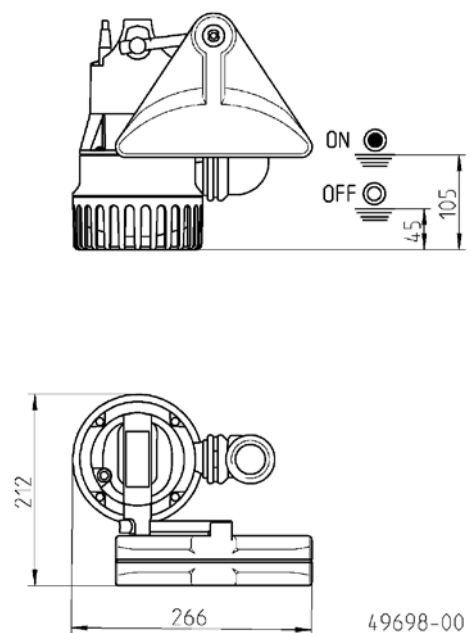

Dimensions and switching points special float (mm)

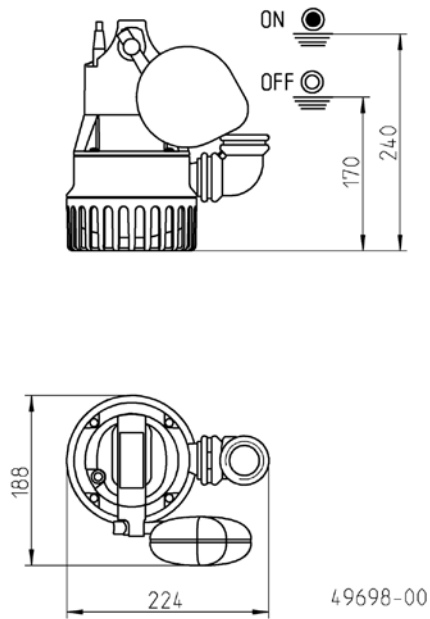

Dimensions GR 32 (mm)

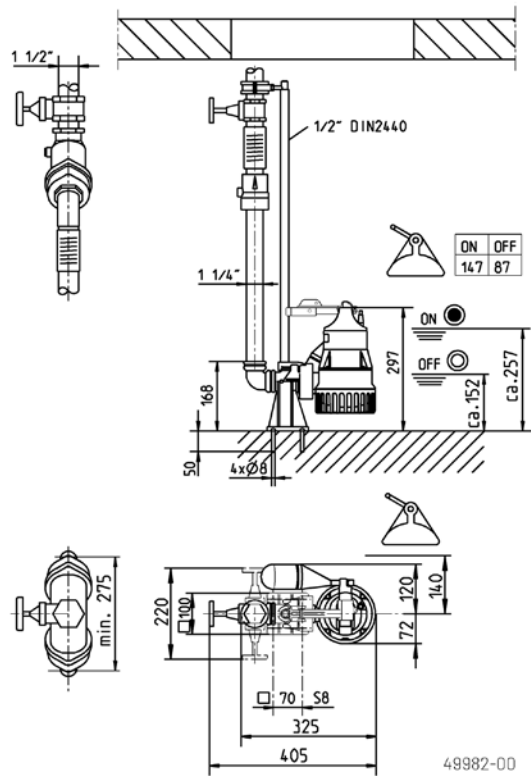

Example of single pump installation with GR

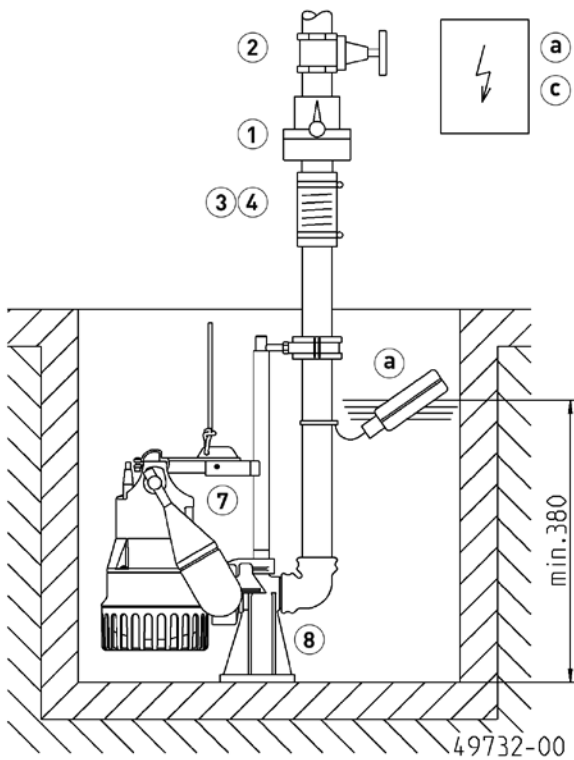

Example of duplex installation

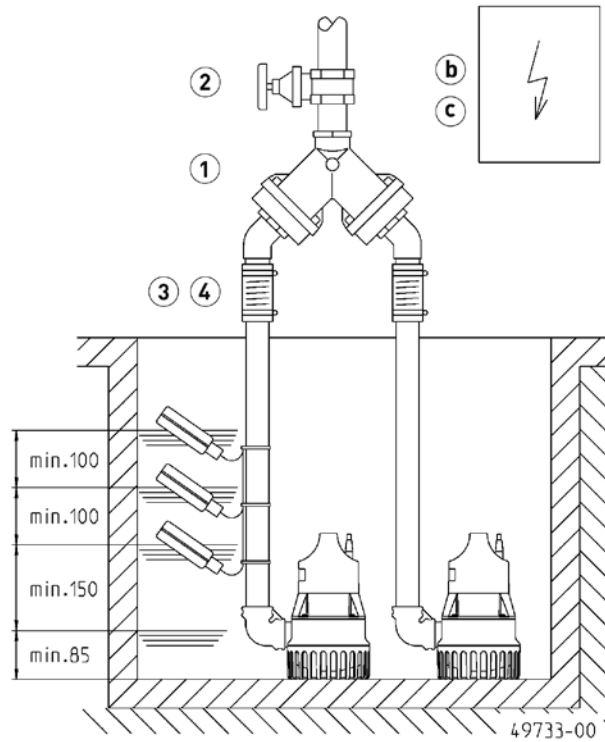

Example of installation and dimensions Easyfix 32 Single (mm)

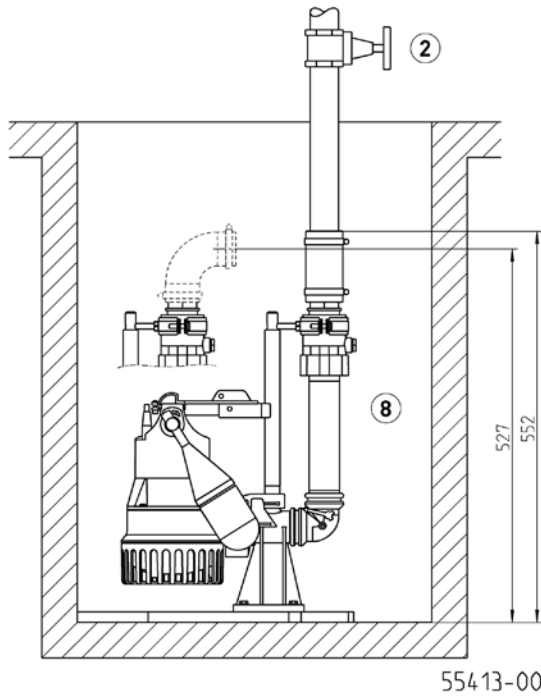



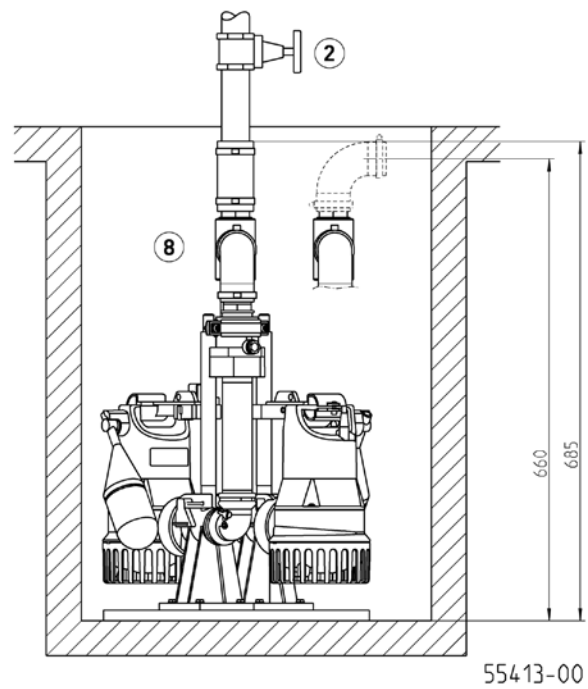



Example of installation and dimensions Easyfix 32 Duo (mm)





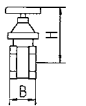

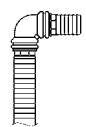

Single unit with GR: sump area min. 40x50 cm or Ø 50 cm
 Single unit without GR: sump area min. 40x40 cm or Ø 40 cm
 Duplex unit with GR: sump area min. 50x50 cm, Ø 60 cm
 Duplex unit without GR: sump area min. 50x50, Ø 55 cm
 Single unit Easyfix 32 Single: sump min. 30x40 cm, Ø 40 cm
 Duplex unit Easyfix 32 Duo: sump min. 45x40 cm, Ø 55 cm
 Duplex unit Easyfix 32 Duo with special float: sump min. 50x50 cm Ø 70 cm

In case of installation beneath the backpressure level the pressure tube must be taken in a loop over the local backup level acc. to EN 12056. Besides, it must be secured with an EN 12050-4-proofed swing-type check valve. Additionally we recommend an alarm system.
 In accordance with EN 12056-4 section 5.1, it has a built-in automatic spare pump or a double attachment included, which ensures that sewage drainage is not interrupted.
 Suspend control unit in a dry room

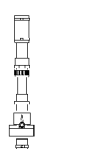

MECHANICAL ACCESSORY

				Code No.
	① Swing-type check valve			
	R32 EN 12050-4	1¼" (DN 32), PN 4	90x90 (HxB)	JP09739
	DR 40 EN 12050-4	1½" (DN 40), PN 4	200x280 (HxB)	JP09155
	Rubber flap DN32	for transportable use	35x35 (HxB)	JP50774
	② Stop valve	1¼" (DN 32), PN 16	110x60 (HxB)	JP44785
	brass, 1½" (DN 40), PN 16		125x60 (HxB)	JP44786
	③ Elastic connection	1¼" (DN 32), PN 3	100x42 (HxD)	JP44773
	④ Hose band clamp	1¼"		JP44765
	⑤ Hose coupling			
	Hose coupling	1¼" (DN 32) brass, for transportable use		JP00327
	House connection	1¼" - 38/32/25		JP44209
	⑥ Hose set	1 1/4" (DN32), 15 m PVC hose c/w elbow		JP43550

MECHANICAL ACCESSORY

			Code No.
	7 Special float	for lower switching points	JP44795
		for narrow chambers (mind. 30x30 od Ø30 cm)	JP40856
	Float fixation	for continuous pump operation	JP42175
		GR 32	JP44000
	8 Guide rail system	Support for guide rail extension ex 2 m sump depth, per m 1 piece	JP28314
		Easyfix 32 Single	JP50308
		Easyfix 32 Duo	JP50307
	9 Connection kit	ready-to-connect installation set	JP50308
		ready-to-connect installation set with control unit for duplex units	JP50307
		DN 32, with telescopable pressure pipe 30-90 cm	JP44609

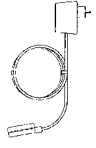
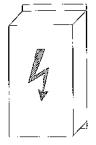
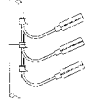
ELECTRICAL ACCESSORY

			Code No.
	a Alarm unit	AG3	JP44891
		AG10	JP44892
		Washing machine stop	
	AW3	subm. ball contact switch, mains dependent, 3 m cable	JP44895
	b Control for duplex units	Control unit HIGHLOGO 2-00 E	JP47996
		Control unit BD 00 E	JP45735
	Level control	Subm. switch pack B	JP16725
		Subm. switch pack BmG	JP16726
	c Rechargeable battery	9 V, for mains independent alarm	JP44850
	d Smart Home	FTJP radio transmitter	JP47209