

# JUNG PUMPEN US 73 EX/103 EX HEAVY DUTY SUBMERSIBLE DRAINAGE PUMPS

EXPLOSION-PROOF

## APPLICATION

These robust centrifugal submersible drainage pumps US 73 Ex and US 103 Ex can be used for the handling of contaminated water containing fibres and particles up to 30 mm size (no stones). The pumps are suitable for mounting in collection chambers and pits located in hazardous areas. Hazardous areas are usually designated where the drainage system is fed from areas with vehicles, car parks, garages, tank farms or laboratories, etc.

Type of protection  II 2 G Ex d IIB T4  
The light weight of the pumps and low power consumption make the unit ideal for dealing with contaminated liquids in an economic manner.

This range of pumps is suitable for stationary use. For easy removal of the pumps from deep sumps we recommend the use of our guide rail systems GR 40 which provide ease of maintenance and inspection. A controllable oil chamber and wear-resistant special mechanical seal ensure a long service life. For automatic monitoring of the oil chamber a seal leak control can be connected.

According to Ex-proof testing regulations, these pumps are provided with winding thermostats and can only be used with the equivalent control unit (see accessories).



US 103 Ex

- Stationary use
- 30 mm free passage
- Controllable oil chamber
- SiC mechanical seal independent of rotation direction
- Replaceable moisture sealed cable inlet

## PERFORMANCE

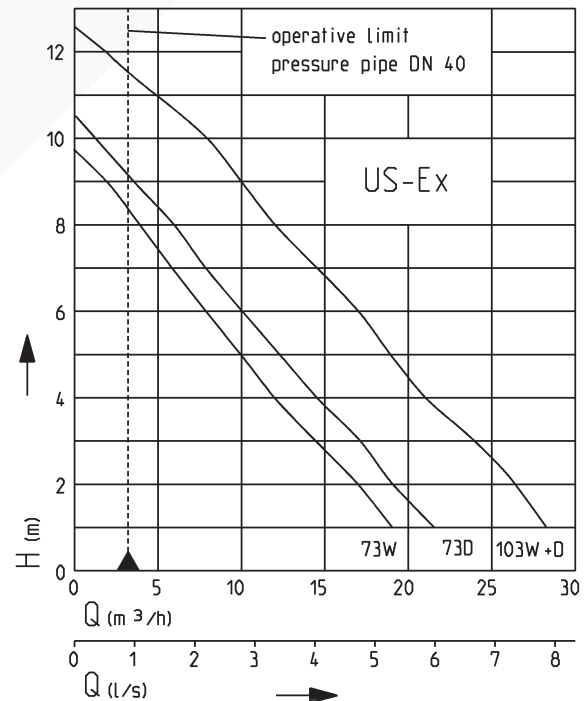

26024-02

We reserve the right to change specifications without notice

Pump performance is subject to ISO 9906 tolerances

The minimum flow velocity in the pressure piping must be 0.7 m/s according to EN 12056.

This data is represented in the performance curve as a limit of application.

# JUNG PUMPEN US 73 EX/103 EX HEAVY DUTY SUBMERSIBLE DRAINAGE PUMPS



EXPLOSION-PROOF

## SUBMERSIBLE SUMP PUMPS

Type	Maximum Height x Width	Discharge branch	Free passage	Cable quality H07RN-F-	Cable length	Weight approx.	Code No.
US 73 Ex E	330 x 215mm	1½"	30 mm	6G1.5	10 m	19.0 kg	JP09292
US 73 Ex D	330 x 215mm	1½"	30 mm	6G1.5	10 m	19.0 kg	JP00595
US 103 Ex E	360 x 215mm	1½"	30 mm	6G1.5	10 m	21.5 kg	JP09294
US 103 Ex D	360 x 215mm	1½"	30 mm	6G1.5	10 m	21.5 kg	JP09293

## PERFORMANCE

Type	Delivery head H [m]	1	2	3	4	5	6	7	8	9	10	12
US 73 Ex E	Flow rate Q [m³/h]	19	17	15	12	10	8	6	4	2		
US 73 Ex D		22	20	17	15	12	10	8	6	4		
US 103 Ex E/D		28	26	23	21	19	17	15	12	10	8	2

## ELECTRICAL DATA

Type	Type of current	Voltage Volt	Motor rating kW P <sub>1</sub>	P <sub>2</sub>	RPM min. <sup>-1</sup>	Current Ampere	Motor protection	Plug
US 73 Ex E	1-phase	1/N/PE~230	0.83	0.50	2510	3.9		without
US 73 Ex D	3-phase	3/PE~400	0.85	0.60	2800	1.4	in control unit + winding thermostats	without
US 103 Ex E	1-phase	1/N/PE~230	1.37	0.98	2700	6.0		without
US 103 Ex D	3-phase	3/PE~400	1.36	1.06	2740	2.4		without

### Example of single pump installation with GR

US 73 + 103 sump area with GR 40 min. 40 x 60 cm  
US 73 + 103 sump area without GR min. 40 x 40 cm (without illustration)

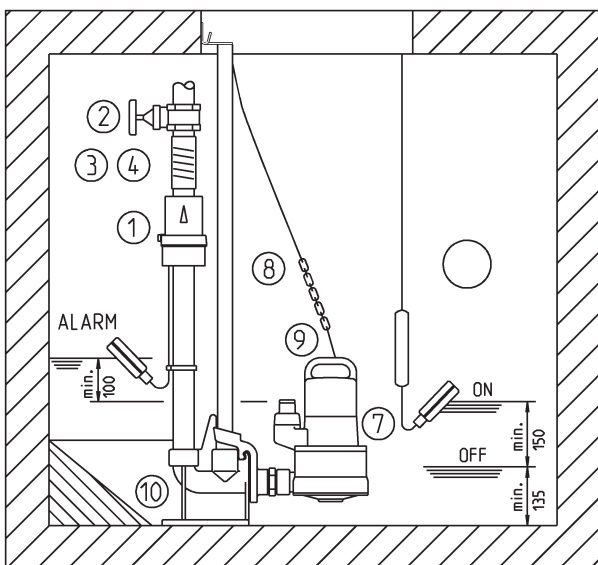
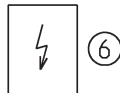

2589www9-05

In case of installation beneath the backpressure level the pressure tube must be taken in a loop over the local backup level acc. to EN 12056. Besides, it must be secured with an EN 12050-4-proofed swing-type check valve. Additionally we recommend an alarm system.

### Example of duplex pump installation

US 73 + 103 sump area without GR min. 40 x 60 cm  
US 73 + 103 sump area with GR 40 min. 60 x 60 cm (without illustration)

Suspend control unit in a dry room.

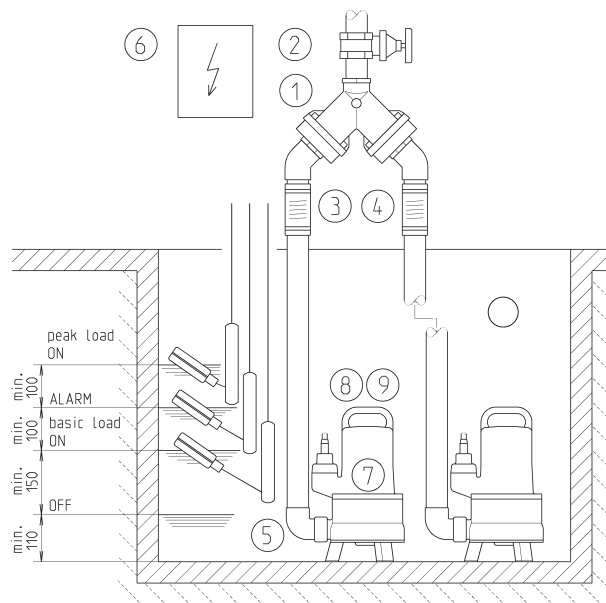

Notice of minimal distance!

25898-03

In accordance with DIN EN 12056-4 section 5.1, it has a built-in automatic spare pump or a double attachment included, which ensures that sewage drainage is not interrupted.







# JUNG PUMPEN US 73 EX/103 EX

## HEAVY DUTY SUBMERSIBLE DRAINAGE PUMPS

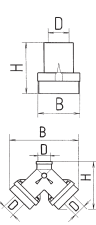
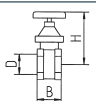

EXPLOSION-PROOF

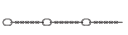
### ACCESSORIES

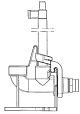
				Code No.	US 73 Ex E	US 73 Ex D	US 103 Ex E	US 103 Ex D
	<b>1</b> <b>Swing-type check valve 1½" (DN 40), PN 4</b>	$\frac{H}{150}$ $\frac{W}{120}$ $\frac{D}{1\frac{1}{2}}$		<b>JP00317</b>	•	•	•	•
	<b>DoppelSwing-type check valve 1½"</b> (DN 40), PN 4 for duplex pump station, DIN EN 12050-4	$\frac{H}{200}$ $\frac{W}{280}$ $\frac{D}{1\frac{1}{2}}$		<b>JP09155</b>	•	•	•	•
	<b>2</b> <b>Stop valve</b> 1½" (DN 40), PN 16	$\frac{H}{125}$ $\frac{W}{\text{max. } 60}$ $\frac{D}{1\frac{1}{2}}$		<b>JP44786</b>	•	•	•	•
	<b>3</b> <b>Elastic connection 1½" (DN 40), PN 4</b>	$\frac{H}{120}$ $\frac{\text{Dia. inside}}{50}$		<b>JP44777</b>	•	•	•	•
	<b>4</b> <b>Hose band clamp 1½"</b>			<b>JP44763</b>	•	•	•	•
	<b>5</b> <b>Elbow 1½"</b>			<b>JP45953</b>	•	•	•	•
	<b>6</b> <b>Separate level controls for single units</b>							
		AD 4 Ex W		<b>JP25901</b>	•			
		AD 8 Ex W		<b>JP25902</b>			•	
		AD 23 Ex		<b>JP09754</b>		•		
		AD 25 Ex		<b>JP09683</b>				•
	Level control	Auxiliary switch unit ExH-A		<b>JP16720</b>	•	•	•	•
		Level control package AmG		<b>JP16719</b>	•	•	•	•
		Dry run protection		<b>JP44603</b>	•	•	•	•
	<b>Control units for duplex unit</b>							
		BD 23 Ex		<b>JP09755</b>		•		
		BD 25 Ex		<b>JP09681</b>				•
	Level control	Auxiliary switch unit ExH-B		<b>JP00295</b>		•		•
		Level control package BmG		<b>JP16726</b>		•		•
		Dry run protection		<b>JP44603</b>		•		•
	Control units for duplex unit with the pumps US 73 Ex W and US 103 Ex W as requested							
	<b>7</b> <b>Seal leak control DKG Ex</b>			<b>JP00249</b>	•	•	•	•
	<b>8</b> <b>Chain</b> certified, stainless steel, 2.5 m, 5 rings, 160 kg (EN 818 mod.)			<b>JP45901</b>	•	•	•	•
	<b>Chain</b> certified, stainless steel, 5.0 m, 8 rings, 160 kg (EN 818 mod.)			<b>JP45902</b>	•	•	•	•
	<b>9</b> <b>Webbing with shackle A 0.6</b>			<b>JP45168</b>	•	•	•	•
	<b>10</b> <b>Guide rail system GR 40</b>			<b>JP25592</b>	•	•	•	•

\* not for duplex units and GR 40

# JUNG PUMPEN US 73 EX/103 EX

## HEAVY DUTY SUBMERSIBLE DRAINAGE PUMPS



EXPLOSION-PROOF

### TECHNICAL DATA

#### Pump

Vertical, single-stage, submersible, with free inlet, volute casing with 1½" (female) discharge branch, open centrifugal impeller, passage 30 mm.

#### Bearings

Common shaft for pump and motor, arranged in ball bearings, lubricated by permanent grease filling.

#### Seal

Silicon carbide mechanical seal, oil chamber and duplex rotary seal towards the motor section, safe to run dry, a seal leak control can be connected.

#### Motor

Special submersible motor, type of enclosure IP 68, insulation class F, winding thermostat protects the motor from overload, tested by PTB for type of protection Ex<sup>Ⓜ</sup> II 2 G EEx d II B T4 automatic activation through control unit only.

#### Materials

Volute and motor casing in GG grey cast iron, vortex impeller, wear plate and pump base in synthetic material (GFK), shaft instainless steel, power supply through rubber insulated flexible cable.

#### Installation

Pump can be installed free standing or together with guide rail system type GR 40, which provides a detachable connection with swing-type check valve mounted in permanent position in discharge pipework.

#### Scope of supply

Pump according to DIN EN 12050 ready for connection with 10 m cable.



Dimensions US 73 Ex and US 103 Ex (mm)

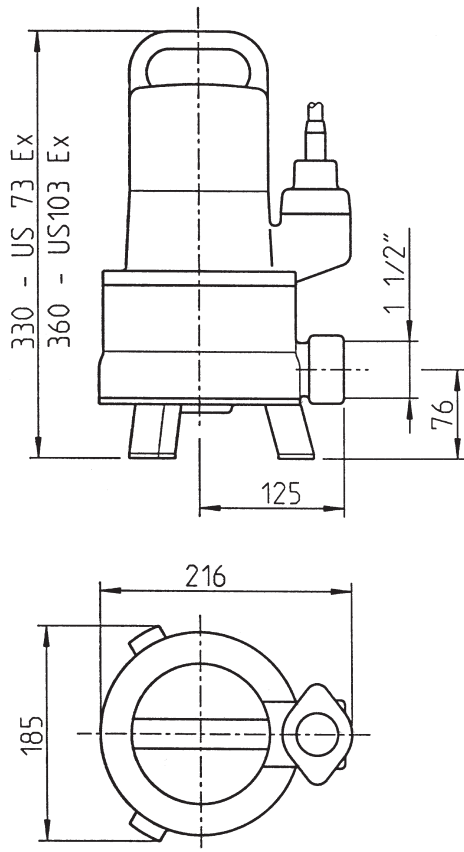

25896-02

Dimensions with GR 40 (mm)

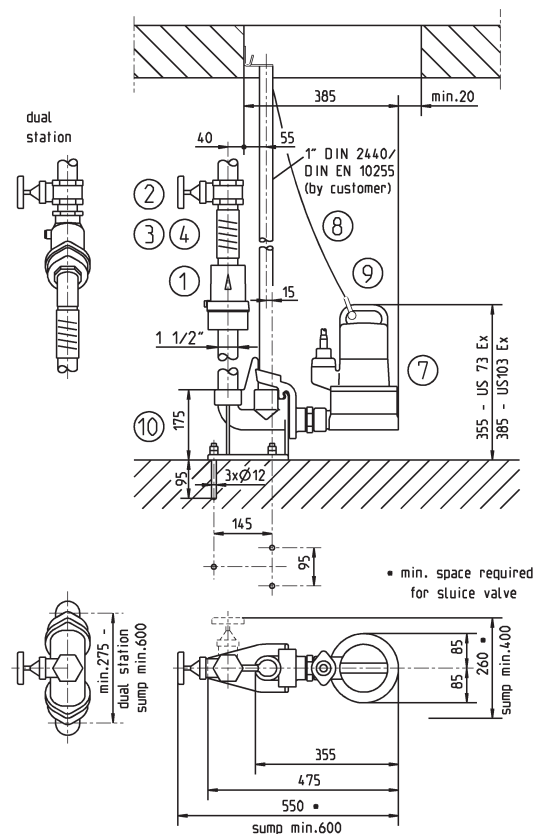

25649-08