

DRAINMINOR 30 (240V) (Wastewater Pumping System)



DrainMinor 30 (240V) Part No. 111
(Wastewater Pumping System.)

General Description:

DrainMinor 30 (240V) features a heavy-duty tank and submersible pump for automatically pumping wastewater from kitchens, teapoints, etc.

Dimensions mm

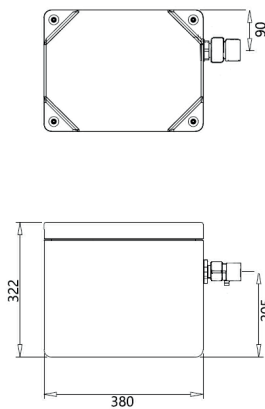

Tank:

Manufactured from recyclable polyethylene and fully rigged with internal pipe work and non-return valve. The lid is held in place with easy-to-remove hand screws and sits on a custom moulded, fitted rubber seal.

Tank Volume: 35.5 litres

Total Approximate Usable Volume - 23.7 litres

Tank Inlets:

To suit site layout, all inverts should be brought into the side of the tank by drilling a hole and using an appropriate tank connector. Minimum invert height 110 mm.

Good for the Environment:



DrainMinor tanks are made from Recyclable Polyethylene.

Recycling polyethylene is highly cost effective and therefore successful. It is greener than incineration, far more eco-friendly than landfill disposal and easier to use when manufacturing products such as toys, recycling bins, envelopes and much more.

Tank Outlet:

Fitted 1¼" BSP male thread discharge outlet (NRV supplied female thread)

Tank Venting:

The tank is fitted with its own vent.

Pump Technology Ltd. - 0118 9821 555 - www.pumptechnology.co.uk

Official Distributor and Stockist Authorised by Jung Pumpen GmbH



PUMP[®] DATA SHEET **DRAINMINOR 30 (240V)**
TECHNOLOGY LTD (Wastewater Pumping System)

Pump:

- Cooling jacket for motor housing
- Flushing device activatable and deactivatable
- Variable discharge branch with closable ventilation
- Run dry protection
- EIP Technology
- Moisture sealed cable inlet
- Fluid temperature 35 °C, temporarily 60 °C (10 min.)



Description:

The heavy duty centrifugal submersible drainage pump U3 KS is suitable for dealing with wastewater and capable of handling soft solids up to 10mm in particle size.

Dimensions/switching points U3 (mm)

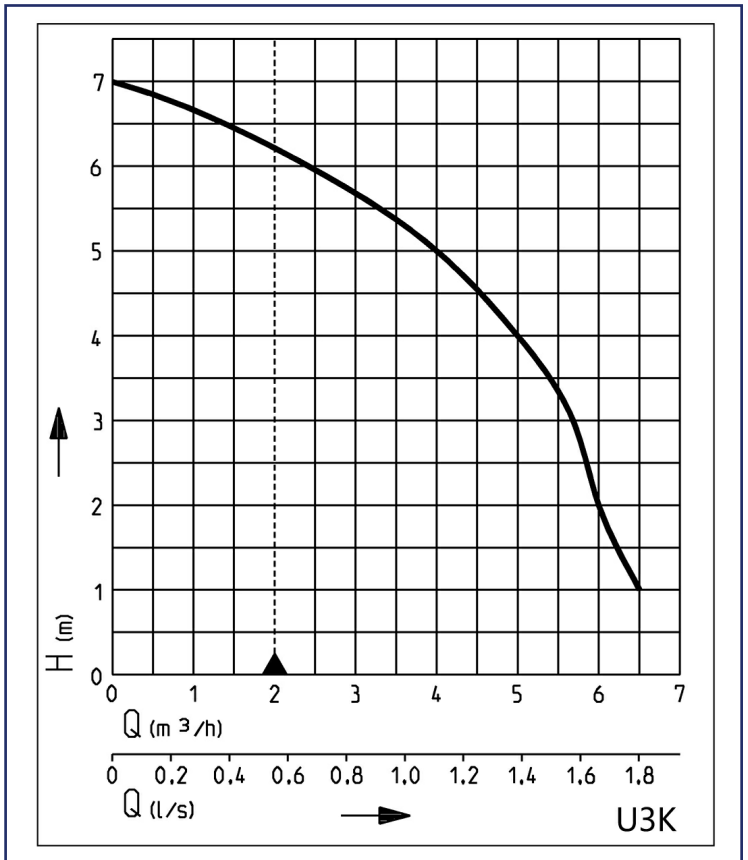
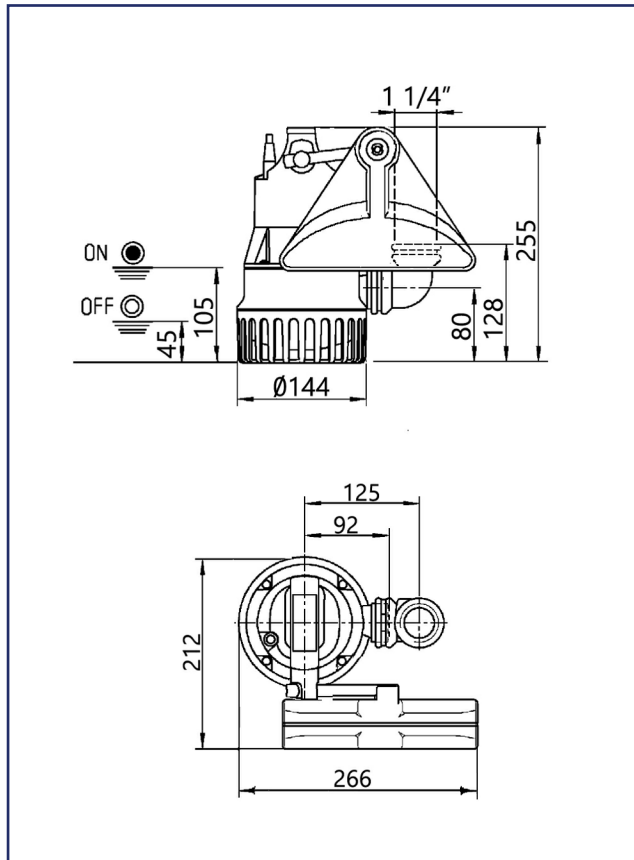

Pump Technology Ltd. - 0118 9821 555 - www.pumptechnology.co.uk

Official Distributor and Stockist Authorised by Jung Pumpen GmbH



Scope of Supply

Pump ready for connection acc. to EN 12050 with 90°, 1¼“ female connection elbow, 4m cable and automatic level float switch.

Mechanical Data

Pump	Vertical single stage	Run dry protection	Yes
Free Passage	10 mm	Shaft	Stainless Steel
Bearing	Ball bearing, grease-lubricated	Impeller	Vortex impeller, GFK
Seal on motor side	Rotary shaft seal	Motor housing	Stainless Steel
Oil chamber	Yes	Pump housing	GRP
Seal on medium side	2-fold rotary shaft seal	Submersible	Yes
		Pressure outlet	1¼”

Electrical Data

Voltage	1/N/PE-230V	Insulation class	F
Motor rating P1	0.32kW	Winding thermostat	Yes
Motor rating P2	0.2kW	Motor protection	Integrated
Current	1.4A	Plug	Safety
Type of enclosure	IP 68		

U3

Type	Code No.	Power line	Wires	Weight
With built-in level control				
U3 KS, 4m cable	JP50000	4m H07RN-F	3G1,0	5.5kg

Notes:

- This unit is for wastewater only
- Ensure the location of the DrainMinor enables the lid to be easily removed for regular inspection and maintenance
- If the discharge pipework connection to a soil stack, manhole etc. is below the discharge outlet of the tank, an anti-syphon unit must be fitted at the highest point of the discharge pipework
- Warranty: The DrainMinor 30 (240V) comes complete with a one year warranty.

Pump Technology Ltd. - 0118 9821 555 - www.pumptechnology.co.uk

Official Distributor and Stockist Authorised by Jung Pumpen GmbH



3 of 3

Pump Technology Ltd. reserves the right to change the specification without prior notice.