

**SIMER**  
UTILITY PUMP



- Removes water down to a level of 2 mm
- Robust cast aluminium housing
- Self-venting starts at a water level of just 5 mm
- Cooling jacket for motor housing
- Replaceable cable inlet
- Accessory: Electronical switch Simer Level Control for automatic pump operation

**DESCRIPTION**

The Simer 5 is a robust utility pump for draining cellars, flat roofs, tennis courts or swimming pools. It can also be used to remove wastewater from building works such as core-hole drilling and concrete cutting. The Simer pump removes unwanted water quickly and efficiently, leaving a residual water level of just 2 mm, while starting to pump at a water level of just 5 mm!

The removable strainer, with a mesh size of 2 mm, reliably protects the hydraulic system from coarse solids. The variable hose connector allows connections to be made quickly and easily.

Connecting the pump permanently to the building's drainage system or using it to protect against back-flow is not permitted, however. Please refer to our UK3 to U6K range of pumps for these types of application.

The electronical switch Simer Level Control can be integrated into the cable inlet and switch the pump on automatically at approx. 7 mm water level. Puddles or floods can be removed immediately. The Simer Level Control operates either in automatic or manual mode.

The dry running of the pump (operation without media) over a period of more than 20 minutes must be avoided!

**PERFORMANCE**

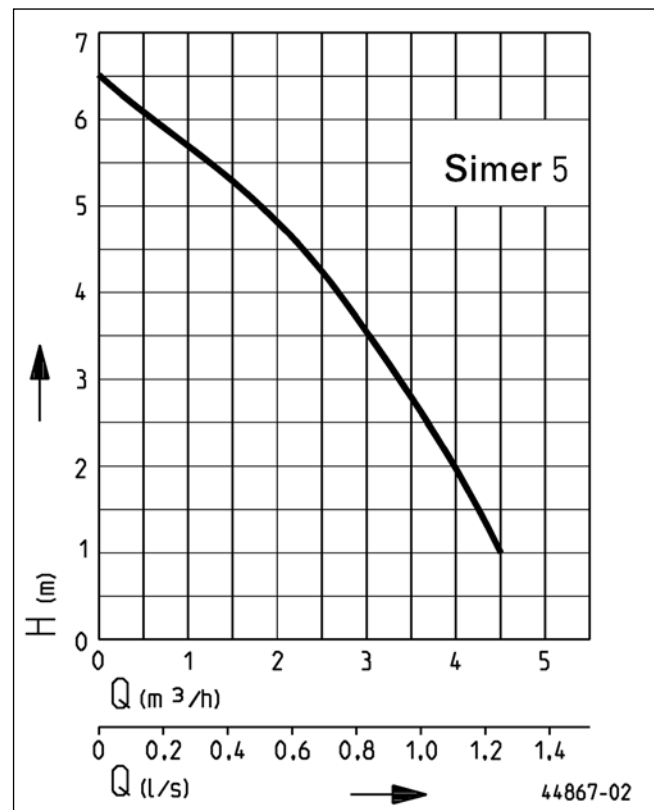

Type	Delivery head H [m]	1	2	3	4	5	6
Simer 5	Flow rate Q [m³/h]	4.3	3.8	3.3	2.6	1.7	0.6

Specifications can be changed without notice. Performance subject to ISO 9906 tolerances.

**SCOPE OF SUPPLY**

Pump, ready to connect, with 1/2"/3/4"/1" (13/19/25 mm) hose

connector, and connecting cable with plug.

**MECHANICAL DATA**

Pump	Vertical single-stage	Impeller	Vortex impeller, zinc die-cast
Bearing	Ball bearings, grease-lubricated	Motor housing	Aluminum
Oil chamber	Yes	Submersible	Yes
Seal on medium side	Mechanical seal	Pressure outlet	1 1/4"
Run dry protection	Yes	Weight	5.2 kg

**ELECTRICAL DATA**

Voltage	1/N/PE-230 V	Type of enclosure	IP 68
Motor rating P1	190 W	Insulation class	B
Current	0.8 A	Winding thermostat	Yes
Power line	10m H07RN8-F	Motor protection	Integrated
Wires	3G1,0	Plug	Safety

**SIMER**



Type	Code No.
Simer 5	OD6601G-05

**Dimensions**

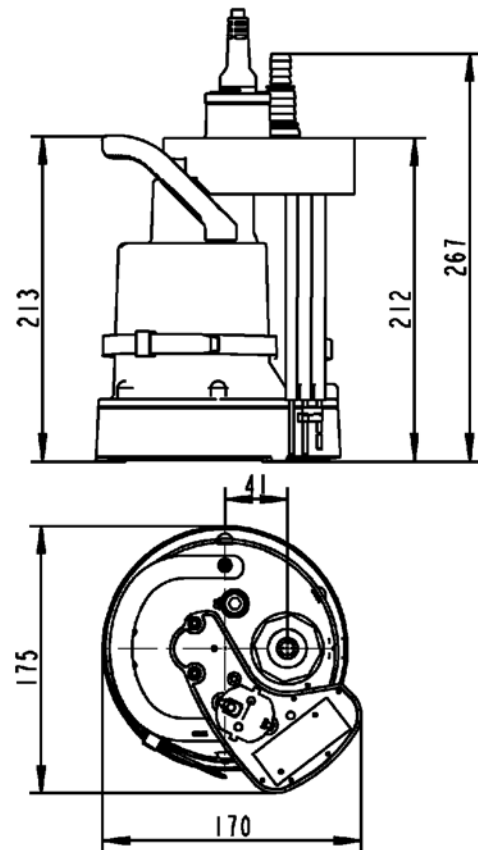
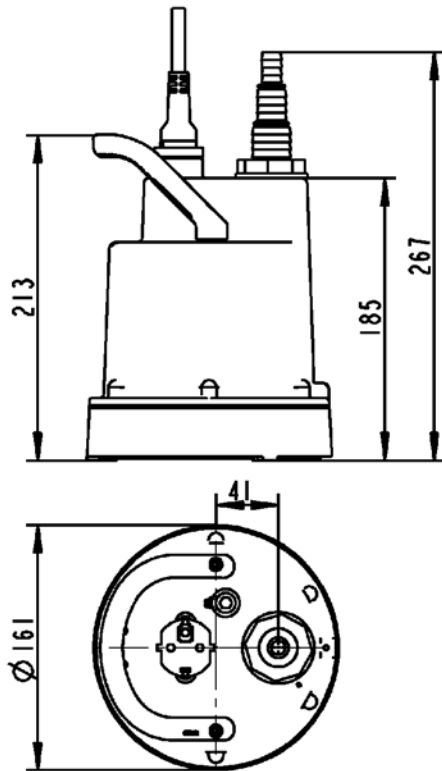
**Dimensions with Simer Level Control**



**MECHANICAL ACCESSORY**

				Code No.
	<b>① Swing-type check valve</b> 1¼" (DN 32)	for transportable use	90x90 (HxB)	<b>JP48845</b>
	<b>② Hose coupling</b> Hose coupling	1¼" (DN 32) brass, for transportable use		<b>JP00327</b>

**ELECTRICAL ACCESSORY**

			Code No.
	<b>ⓐ Level control</b>	Simer Level Control (ON 7 mm / OFF 2 mm)	<b>JP46884</b>