

# MULTICUT 08

## SEWAGE PUMPS



- Reliable solids transport due to improved cutting technology
- External adjustable cutting mechanism
- Controllable oil chamber
- Installed motor protection
- SiC mechanical seal
- Independent of sense of rotation
- Moisture-sealed cable inlet with plug-in cable connection
- Ex-version: Impeller and replaceable wear plate made from fibre-glass reinforced plastic

### DESCRIPTION

Centrifugal submersible sewage pumps fitted with the MultiCut cutting system are used as stationary appliances for backpressure protection of detached houses. They are suitable for pumping domestic wastewater with the usual additions (as specified in German standard DIN 1986, Part 3).

For pumping from ducts which are connected to the public sewer system, explosion-proof submersible pumps of have to be used. On account of the upstream cutting system, the pressurised line as from DN 32 - as from DN 80 minimum without cutting system - may be routed parallel to the terrain.

Operating conditions up to a temperature of the material to be transported of 40° celsius, submerged motor: continuous operation (S1), emerged motor: intermittent operation (S3)(e.g. 35% = 3.5 min. operation, 6.5 min. break).

The unique MultiCut cutting system ensures a maximum of operational safety at outstanding delivery characteristics. Fitted with a cutter plate made of hardened stainless steel and a three-bladed knife, it disintegrates coarse additions in the wastewater with more than 200,000 cutting processes per minute before they can get into the pump hydraulics. Solids which cannot be transported are rejected outside of the pump by the cutting rotor as the cutting system is located upstream from the pump hydraulics. Specifically arranged grooves on the cutter plate ensure additional safety as the cutting unit is permanently cleaned automatically during the delivery.

### PERFORMANCE

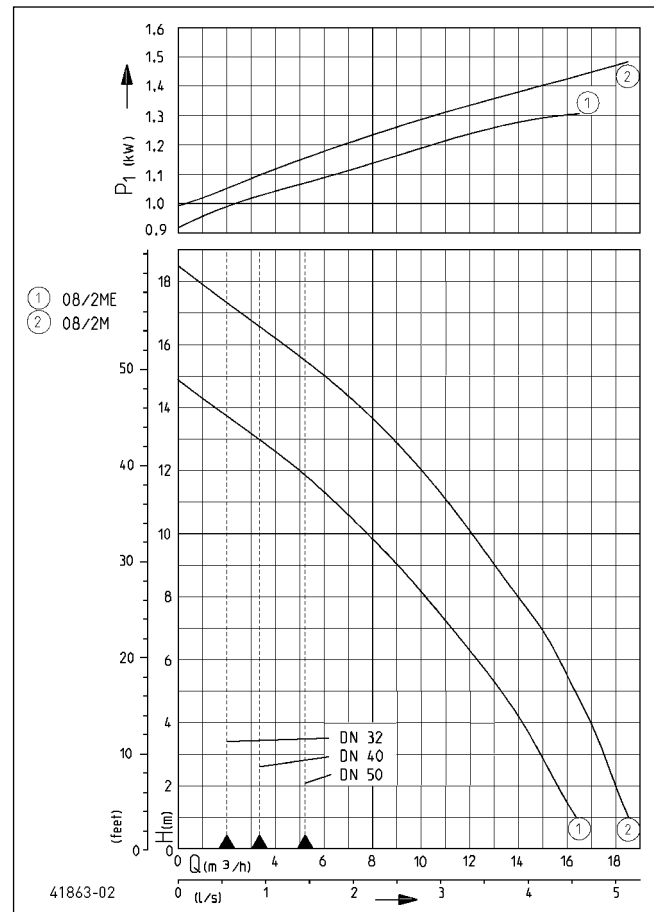

Type	Delivery head H [m]	1	2	3	4	5	6	7	8	9	10	11	12	13	14	15	16
08/2 ME/MES	Flow rate Q [m³/h]	16.5	15.5	15.0	14.0	13.0	12.0	11.0	10.0	9.0	7.5	6.5	5.0	3.5	1.5		
08/2 M/MS		18.5	18.0	17.5	17.0	16.5	15.5	15.0	14.0	13.0	12.0	11.0	10.0	9.0	7.5	6.0	4.5

Specifications can be changed without notice. Performance subject to ISO 9906 tolerances. The minimum flow velocity in the pressure piping must be 0.7 m/s according to EN 12056. This data is represented in the performance curve as a limit of application.



# MULTICUT 08

## SEWAGE PUMPS



### SCOPE OF SUPPLY

Pump ready for connection according to EN 12050 with 10 m cable and CEE plug 16 A (type M + MS) or schuko plug (type ME + MES). Ex II 2 G Ex db IIB T4 Gb

For pumps with automatic switch control, the pump base are included in delivery. As Ex-pump with 10 m cable without plug. Complete motor protection only in connection with appropriate controls units (see accessories).

### MECHANICAL DATA

Pump	Vertical single-stage	Run dry protection	Yes
Bearing	Ball bearings, grease-lubricated	Impeller	Vortex impeller, GFK
Seal on motor side	Duplex rotary shaft seals	Pump housing	Grey cast iron
Oil chamber	Yes	Submersible	Yes
Seal on medium side	SiC mechanical seal	Pressure outlet	DN 32

### ELECTRICAL DATA

Power line	10m H07RN-F	Winding thermostat	Yes
Type of enclosure	IP 68		

### MULTICUT 08

Type	Code No.	Voltage	Motor rating P1	Motor rating P2	Current	Wires	Motor protection	Plug	S3	Motor housing	Weight
<b>Without level control</b>											
08/2 ME	JP50342	1/N/PE~230 V	1.37 kW	0.98 kW	6.0 A	3G1,0	In motor	Safety	10 %	Stainless steel	16.2 kg
08/2 M	JP50344	3/PE~400 V	1.65 kW	1.24 kW	2.8 A	4G1,0	In motor	CEE-16A	10 %	Stainless steel	16.5 kg
08/2 M, Ex	JP50346	3/PE~400 V	1.65 kW	1.24 kW	2.8 A	6G1,5	With control unit	Without	35 %	Grey cast iron	28.0 kg
<b>With built-in level control</b>											
08/2 MES	JP50343	1/N/PE~230 V	1.37 kW	0.98 kW	6.0 A	3G1,0	In motor	Safety	10 %	Stainless steel	16.6 kg
08/2 MS	JP50345	3/PE~400 V	1.65 kW	1.24 kW	2.8 A	4G1,0	In motor	CEE-16A	10 %	Stainless steel	17.2 kg

### Dimensions 08/2 M (mm)

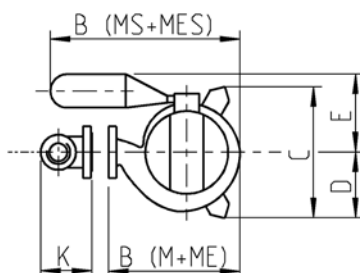
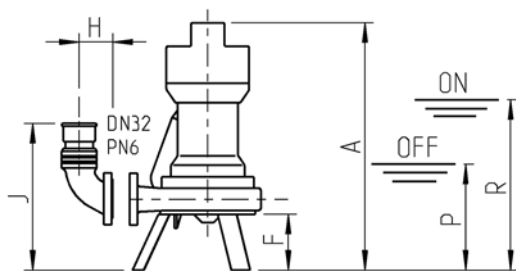

25981-09

Typ	A	B	C	D	E	F	G	H	J	K	P	R
08/2M +ME	445	235	230	-	-	100	128	60	265	90	-	-
08/2MS+MES	445	340	-	115	140	100	128	60	265	90	190	305

### Dimensions 08/2 M, EX (mm)

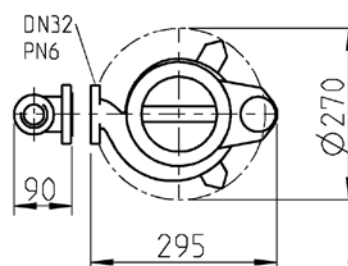
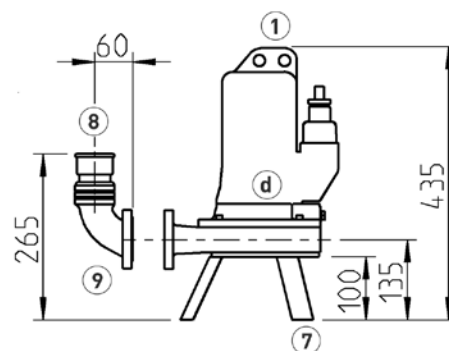

43067-02

Example of pump base installation

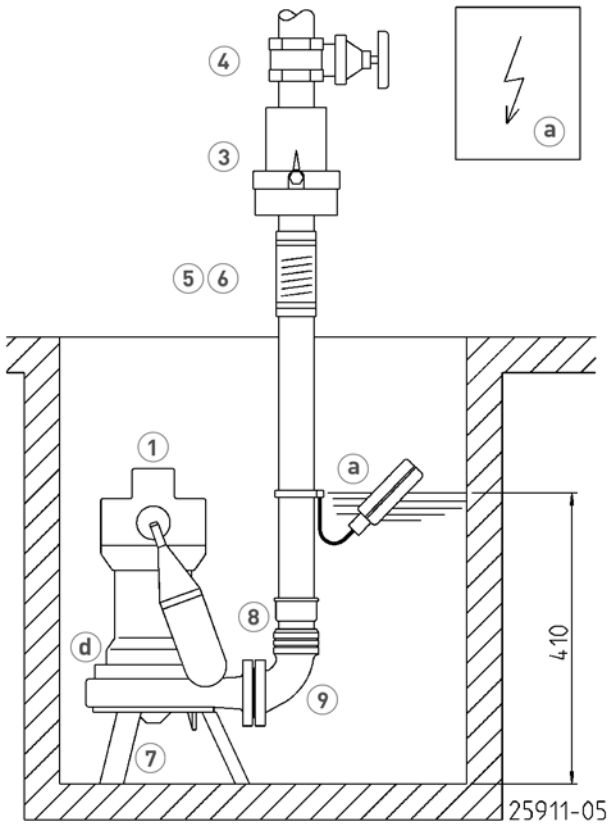

Example of pump base installation with ex-proof

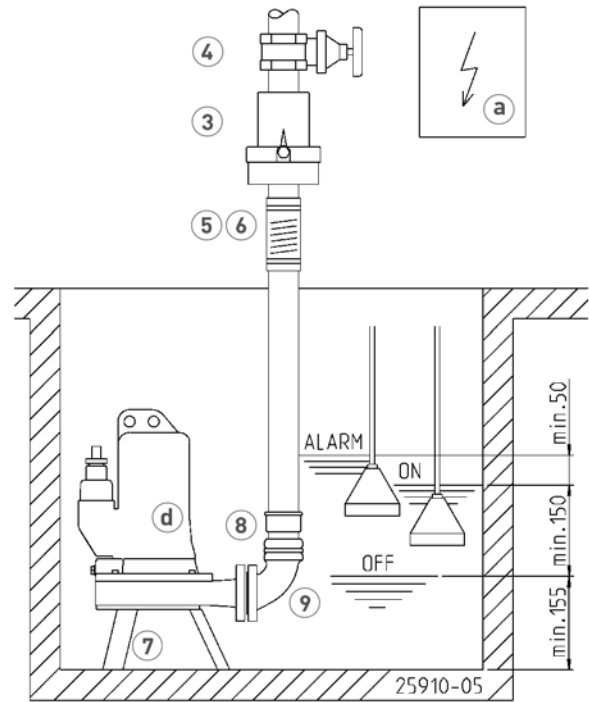

Example of guide rail installation

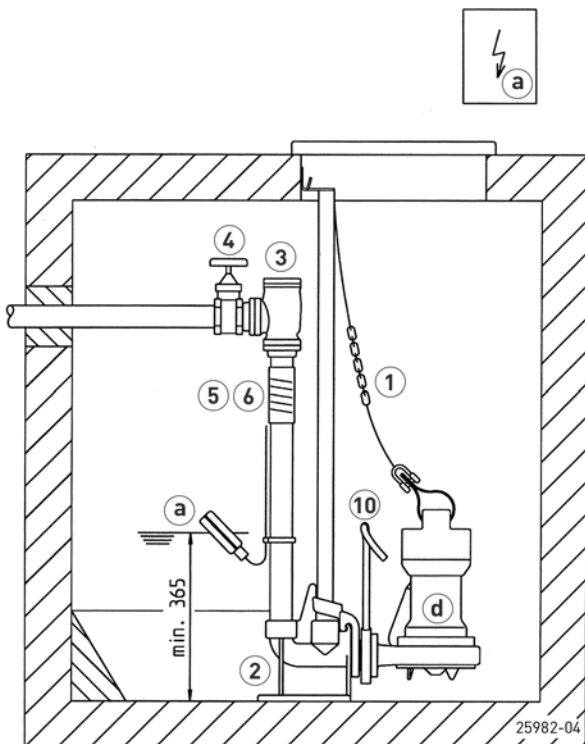

Example of guide rail installation with ex-proof

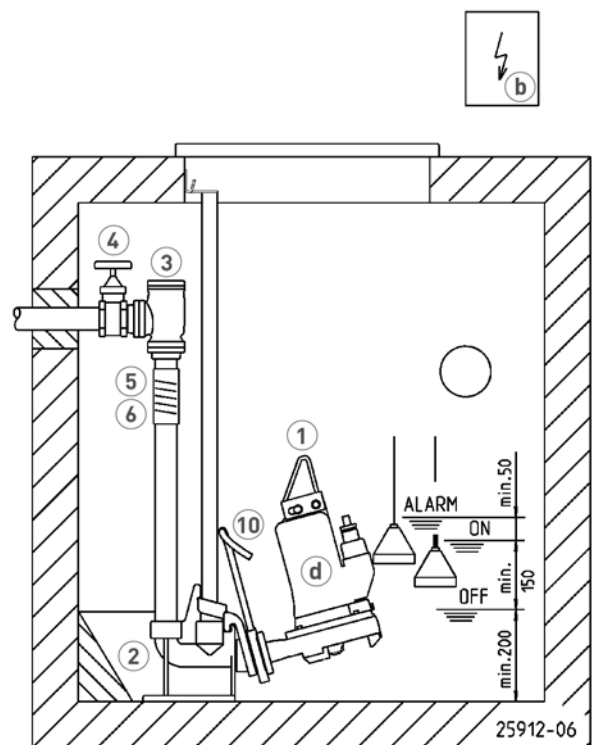

# MULTICUT 08

## SEWAGE PUMPS



Example of guide rail installation

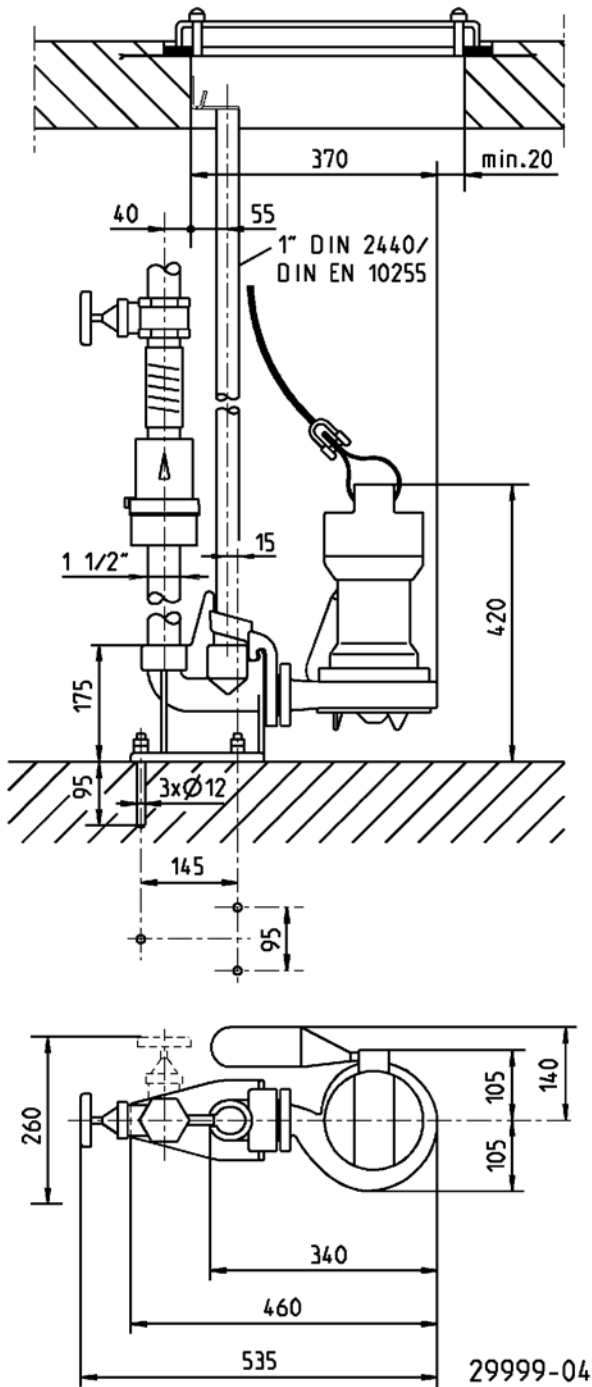





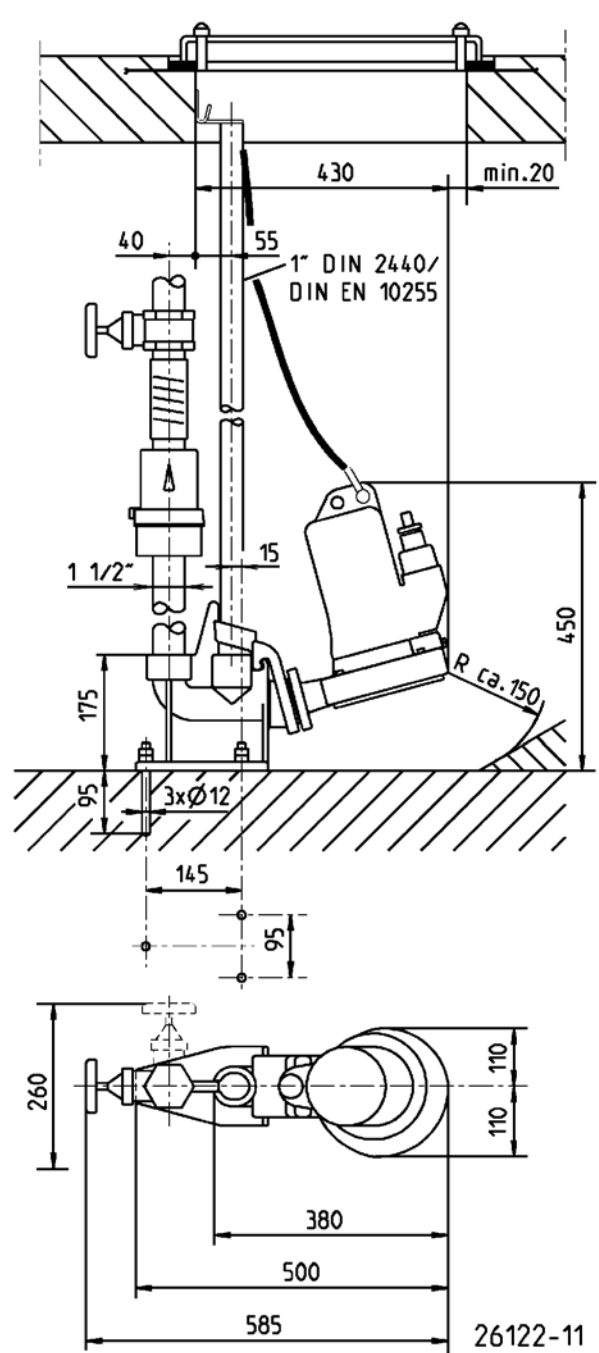

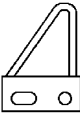

Single unit - min. sump (cm)  
 without GR: 40x40  
 with GR and swing-type check valve: 40x65  
 with GR and ball-type check valve: 40x65

Example of guide rail installation with ex-proof



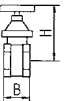



Duplex unit - min. sump (cm)  
 without GR and swing-type check valve, check valve: 60x60  
 without GR and elbow-ball check valve: 60x80  
 with GR and duplex swing-type check valve: 60x60  
 with GR and duplex swing-type check valve or -valve: 65x85

MECHANICAL ACCESSORY

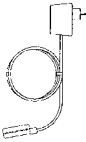
			Code No.
	<b>① Chain</b>	certified, 2.5 m, 320 kg, 5 rings (EN 818 mod.) certified, 5.0 m, 320 kg, 8 rings (EN 818 mod.) certified, 7.5 m, 320 kg, 11 rings (EN 818 mod.) Shackle, certified, 630 kg, stainless steel Pump hanging (08 Ex - 100...)	JP45901 JP45902 JP47365 JP45904 JP45925
	<b>Webbing</b>	with shackle	JP45168
	<b>② Guide rail system</b>		
	GR 35	1 1/2" female thread for MultiCut pumps	JP14094
	GR 35	1 1/2" female thread for MultiCut 08 without Ex-proof	JP29953
	Guide rail 1"	1500 mm	JP48937
	Guide rail 1"	2000 mm	JP48938
	Guide rail 1"	2500 mm	JP48939
	Guide rail 1"	3000 mm	JP48940
	<b>③ Swing-type check valve</b>		
	R40 EN 12050-4	1/2" (DN 40), PN 4	150x120 (HxB) JP00317
	DR 40 EN 12050-4	1/2" (DN 40), PN 4	200x280 (HxB) JP09155
	R50 EN 12050-4	2" (DN 50), PN 4	150x120 (HxB) JP00326
	<b>Ball-type check valve</b>		
	KE40 EN 12050-4	1/2" (DN 40), PN 6	170x125 (HxB) JP47974
	K50 EN 12050-4	2" (DN 50), PN 6	185x155 (HxB) JP44782
	<b>④ Stop valve</b>	brass, 1/2" (DN 40), PN 16 stainless steel, 1/2" (DN 40), PN 16 brass, 2" (DN 50), PN 16	125x60 (HxB) JP44786 125x80 (HxB) JP48403 140x70 (HxB) JP44787
	<b>⑤ Elastic connection</b>	1/2" (DN 40), PN 4 2" (DN 50), PN 4	120x50 (HxD) JP44777 150x63 (HxD) JP44775
	<b>⑥ Hose band clamp</b>	1/2" 2"	JP44763 JP44764
	<b>⑦ Bases</b>	(for 08/2 MS and MES in scope of supply)	JP44759
	<b>Retaining plate</b>	in connection with startic-air level control	JP23100
	<b>⑧ Reducing socket</b>	1/4"-1/2" 1/4"-2" 1 1/2"-2" for guide rail system GR 35	JP44769 JP44772 JP44776
	<b>⑨ Pipe connection</b>	1 1/4" (female thread)	JP16870
	<b>⑩ Flushing tube</b>	Type I-M stainless steel with connection flange (not PKS-B 800) Type 0	JP40333 JP45408

**ELECTRICAL ACCESSORY**

			Code No.
	<b>a Alarm unit</b>		
	AG3	subm. ball contact switch, mains dependent, potential-free contact, 3 m cable	JP44891
	AG10	subm. ball contact switch, mains dependent, potential-free contact, 9.5 m cable	JP44892
	<b>b Control for single units</b>		
	Control unit HIGHLOGO 1-00 E	230 V	JP47987
	Control unit AD 00 E	230 V	JP00289
	+ startic air level control		JP17101
	Control unit HIGHLOGO 1-25 LC	400 V	JP47984
	Control unit AD 25 ExM, TLS	400 V	JP43159
	<b>Control for duplex units</b>		
Control unit HIGHLOGO 2-00 E	230 V	JP47996	
Control unit BD 00 E	230 V, for pumps U3-U6, US 62-105, UV3, UV 300, 08/2 ME	JP45735	
	+ startic air level control		JP17101
	Control unit HIGHLOGO 2-25 LC	400 V	JP47993
	Control unit BD 25 ExM, TLS	400 V	JP43165
	<b>c Rechargeable battery</b>	9 V, for mains independent alarm	JP44850
	<b>d Seal leak detector</b>	DKG	JP44900
		DKG Ex for explosion-proof pumps	JP00249
	<b>Smart Home</b>	FTJP radio transmitter	JP47209