

HEBEFIX

ABOVE FLOOR TANK



- Disposal of dirty water from hand basin, shower, bathtub, washing machine
- Condensate from condensing boilers
- Backwash water from softeners
- Easy opening of the cover without dismantling a siphon or an inlet pipe
- Swing-type check valve and activated carbon filter are scope of supply
- Wall or floor installation
- Pressure pipe on the right or left side
- Alarm system possible

DESCRIPTION

The Hebefix above-floor tank is the ideal solution if a washbasin or sink is to be installed and there is no waste water pipe nearby. It is quick to install and offers ideal solutions in combination with the U3KS, U3KS special or U5KS drainage pumps.

The drainage pump intended for the Hebefix is connected to the prepared pipe connection and automatically pumps the incoming grey water to the next disposal pipe. The tank has four inlet sleeves. This means that a drain can be created at any desired location, even below the backwater level, without costly bricklaying work. By means of the lower additional inlets on both sides (H=100 mm) and a special float for lower switching heights (U3 only), a backflow-proof shower can be connected.

The supplied activated carbon filter reduces odours. The installation of an alarm unit is recommended. The automatic alarm AGR or AWR (alarm device with washing machine cutoff) signalizes an unacceptably high water level and the AWR switches off the connected machine. If the special float is installed at the same time, the special fastener for alarm is required.

PERFORMANCE

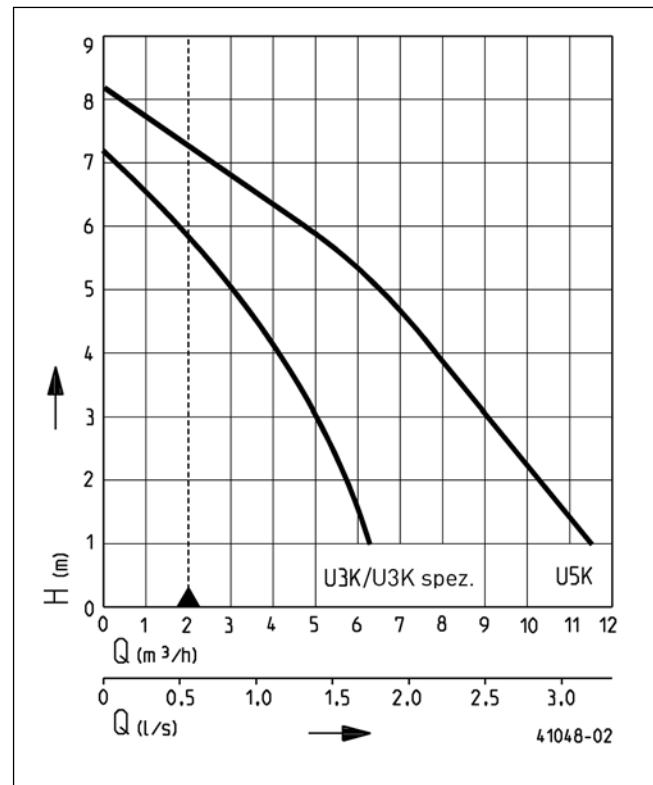

Specifications can be changed without notice. Performance subject to ISO 9906 tolerances. The minimum flow velocity in the pressure piping must be 0.7 m/s according to EN 12056. This data is represented in the performance curve as a limit of application.



HEBEFIX

ABOVE FLOOR TANK



SCOPE OF SUPPLY

Plastic tank (ABS) without pump with integrated connection hose, clamps, swing-type check valve R32, activated carbon

filter, rubber feet and wall attachment parts. The unit is in conformity with the specification of EN 12050.

MECHANICAL DATA

Tank capacity	26 l	Weight	3.2 kg
---------------	------	--------	--------

HEBEFIX

Type	Code No.
Hebefix	JP50210

POSSIBLE PUMPS

Hebefix	U5KS
U3KS/U3KS special	

Dimensions (mm)

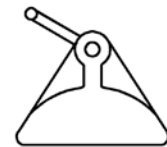
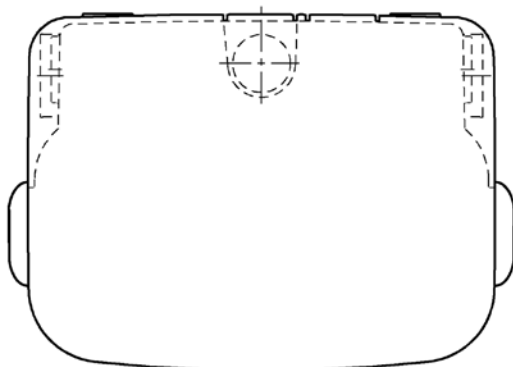
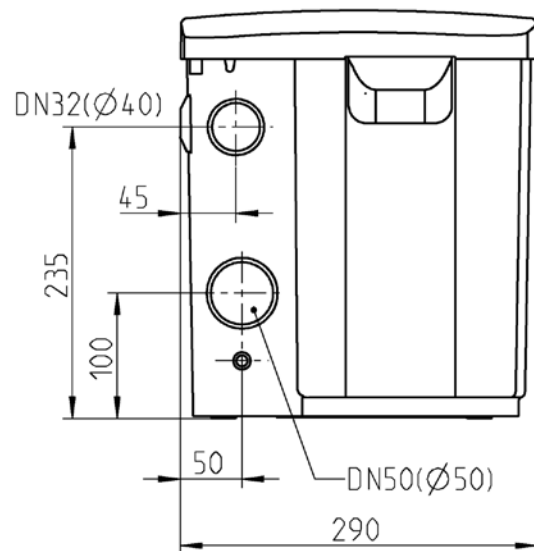
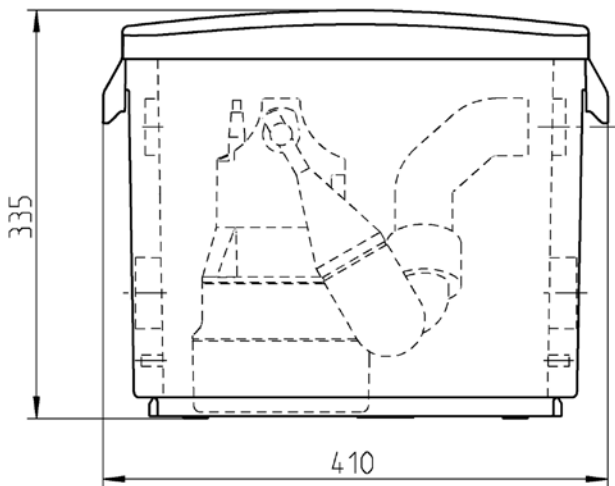

	ON	OFF
U3	220	110
U5	245	140

	ON	OFF
U3	110	50

49518-01

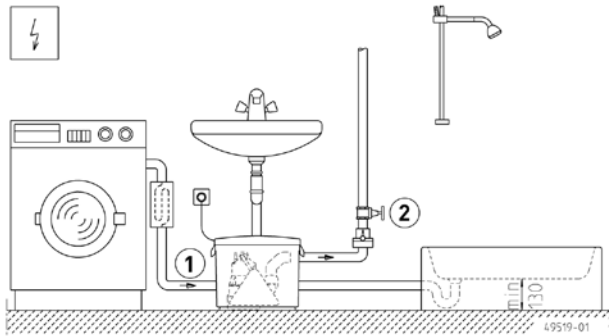

Example of installation Hebefix (floor mounted)



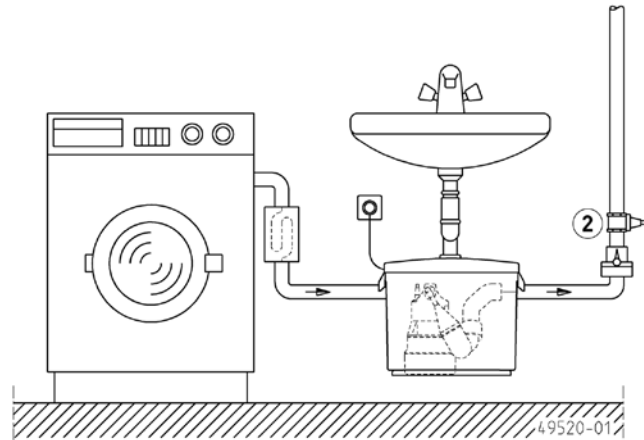

Hebefix (wall mounted)

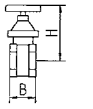

MECHANICAL ACCESSORY

			Code No.
	1 Special float	for lower switching points	JP44795
	2 Stop valve	1/4" (DN 32), PN 16 110x60 (HxB)	JP44785
	Ball valve	1/4", PVC, for aggressive media 105x155 (HxB)	JP46111

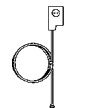
ELECTRICAL ACCESSORY

			Code No.
	a Alarm unit		
	AGR	reed switch, mains dependent, potential-free contact, 4 m cable	JP44893
	Washing machine stop		
	AWR	reed switch, mains dependent, 3 m cable	JP44897
	Fastener for alarm switch	(only U3KS, U5KS and U6KS with special float switch)	JP28191
	b Rechargeable battery	9 V, for mains independent alarm	JP44850