



JUNG PUMPEN COMPLI

RESIDENTIAL TECHNOLOGY

SEWAGE LIFTING STATIONS

JUNG PUMPEN COMPLI SEWAGE LIFTING STATIONS

COMPLI – THE RIGHT UNIT FOR EVERY APPLICATION



SINGLE UNITS – COMPACT AND EASY TO INSTALL



COMPLI 300 E – THE SMALLEST AND THE LIGHTEST

This sewage lifting station is the smallest in our compli range. It has been specifically designed for the disposal of sewage from housing units such as basement dwellings. Due to its extremely compact tank dimensions and the numerous connection options, it is very versatile.



COMPLI 400 – THE FIRST CHOICE FOR THE SINGLE-FAMILY HOUSE

Easy to operate, space-saving assembly, easy installation – it is no coincidence that the compli 400 is already an inherent part of the wastewater disposal system in more and more single-family houses.

Even in flood-prone areas this floodable system continues to dispose of domestic wastewater reliably and around the clock.



COMPLI 500 – FOR THOSE WHO WANT MORE

For larger wastewater flows, the compli 500 ensures reliable disposal with a larger tank capacity (115 l). As for all compli systems, the user-friendly controls guarantee dependable operation.

Different motor ratings are available to suit the particular performance requirements.



DUPLEX UNITS - RELIABILITY X 2



COMPLI 1000 – FOR RELIABILITY TO THE POWER OF TWO

For several housing units or for commercial buildings such as hotels, pubs or restaurants, not only more power but also more reliability is required. The compli 1000 is therefore a duplex unit with two pumps on one tank.

These pumps operate alternately, or work together during periods of peak load.

COMPLI 1200 – FOR MORE VOLUME

The compli 1200, with a tank capacity of 350 l, provides the ideal solution for several housing units, business establishments or hospitals. It is easy to install and maintain.

The inlet at the back can be installed for variable height (560-700 mm) and be swivel-mounted (180°).

COMPLI 1500/COMPLI 2500 – TO MEET THE GREATEST DEMANDS

For large industrial and municipal wastewater volumes or for the connection of entire streets or shopping centers, an especially large tank capacity is required. With a total volume of 1000 l and correspondingly powerful MultiStream pumps, the compli 2500 is the largest sewage lifting station.

These systems are available with either two tanks (compli 2500) or one tank (compli 1500 with 500 l).

JUNG PUMPEN COMPLI SEWAGE LIFTING STATIONS



SEWAGE LIFTING STATIONS FOR SPECIAL APPLICATION



COMPLI 100, 500 AND 1000 MULTICUT

The sewage lifting stations with the MultiCut cutting system were specially developed for the disposal of sewage from weekend cottages, houseboats, production halls and mobile sanitary units.

The MultiCut cutting system breaks up the common solid components found in domestic wastewater, enabling the use of smaller diameter pressure pipes.



COMPLI 1200, 1400 UND 1600 - IN STAINLESS STEEL

The sewage lifting stations are specifically designed for large industrial and municipal wastewater volumes where special safety regulations have to be met, e. g. at underground stations, airports or parking decks.

COMPLI SEWAGE LIFTING STATIONS READY TO PLUG-IN • POWERFUL

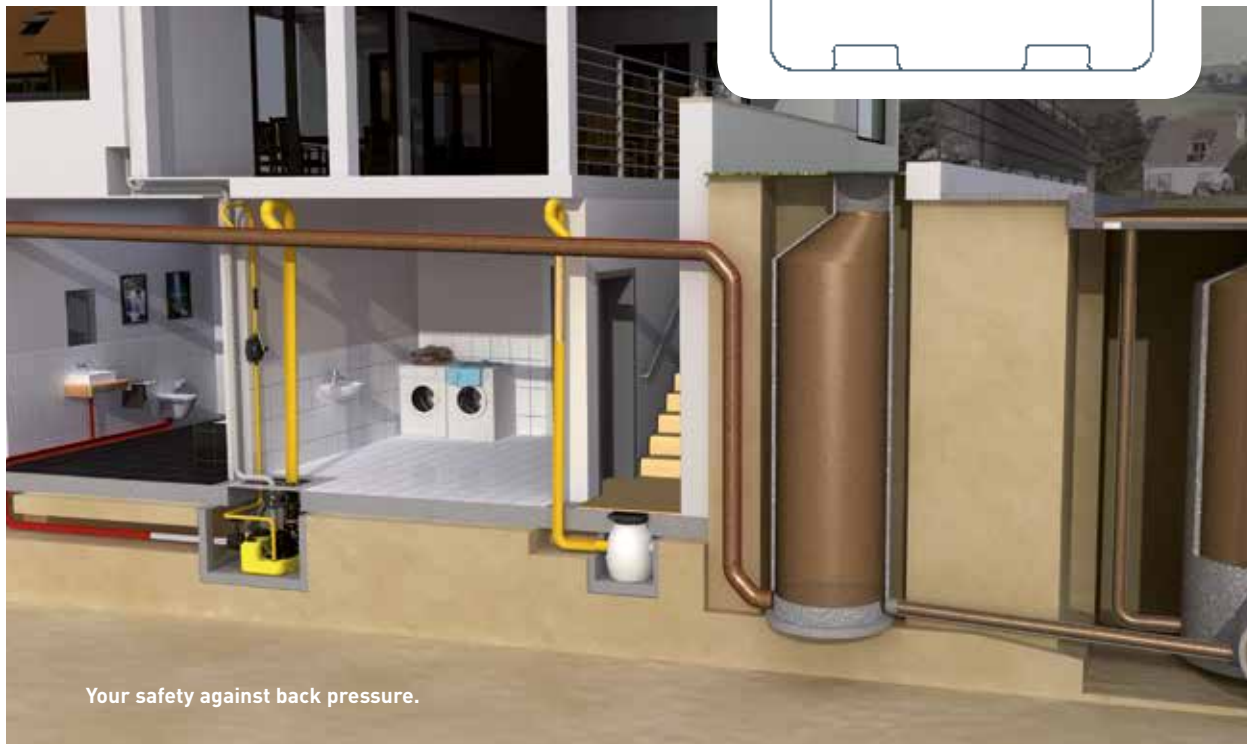
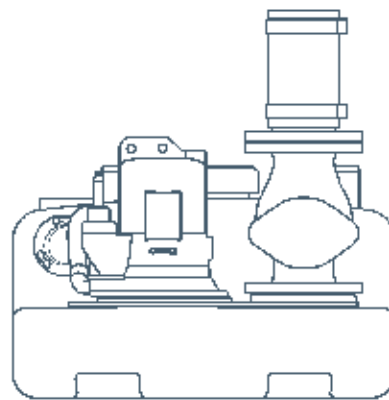

NUMBERS - DATES - FACTS

compli	Dimensions h x w x d [mm]	Tank capacity [l]	Hmax [m]	Qmax [m³/h]	Free passage [mm]	Inlet height [mm]
Single units						
300 E	445 x 525 x 525	50	10,5	29	50	180
400	445 x 650 x 595	64	7	48	70	180/250
500	600 x 835 x 690	115	20	76	70	variable
100 MultiCut	450 x 500 x 636	38	24	18	7	180/250
500 MultiCut	600 x 835 x 690	115	24	18	7	variable
Duplex units						
1000	600 x 835 x 690	115	20	76	70	variable
1200	800 x 910 x 1010	350	20	76	70	560-700
1500	820 x 910 x 1610	500	22	100	70 / 100	700
2500	820 x 1955 x 1610	2 x 500	22	100	70 / 100	700
1000 MultiCut	600 x 835 x 690	115	24	18	7	variable
Stainless steel units						
1200 Stainless steel	880 x 770 x 1142	270	16	122	80 / 100	700
1400 Stainless steel	985 x 970 x 1375	540	16	122	80 / 100	800
1600 Stainless steel	985 x 970 x 1882	900	16	122	80 / 100	800



Height adjustable clamping flange
complli 400



COMPLI SEWAGE LIFTING STATIONS - CONVINCING QUALITY



PVC inlet sluice valve
DN 100 or DN 150, with pipe sockets
bonded in, for the time-saving and
space-saving direct connection to the
inlet clamping flange.

- ▶ **Ready to plug-in**
 - no electrician required
 - also available with swing-type check valve
- ▶ **Height adjustable clamping flange**
 - quick adjustment to suit the wastewater situation on site
- ▶ **Easy installation**
 - due to flexible connection facilities
- ▶ **Protection from moisture penetration**
 - due to moisture sealed cable inlet
- ▶ **Inlet-optimised tank base**
 - less maintenance required
- ▶ **Large cleaning opening**
 - maintenance-friendly
- ▶ **Smooth running and quiet**
 - due to cast support platform
- ▶ **Guided float switch**
 - for reliable, clearly defined switching points
- ▶ **Easy-to-operate controls**
 - clear layout of display and control elements
- ▶ **LGA type tested and monitored**
- ▶ **All components „Made in Germany“**

Further information regarding
sewage lifting stations at
www.jung-pumpen.de

