

PLANCOFIX

FLOOR DRAINAGE PUMPS

- Installation depth 10.5 cm / 9 cm
- Inlet from above through the floor drain or from the side
- Drain can be tiled or in stainless steel
- Seal collar for attaching to the customer's thin-bed waterproofing system
- Easy cleaning and maintenance
- Optional secondary drain
- Plancofix plus < 30 dB(A)

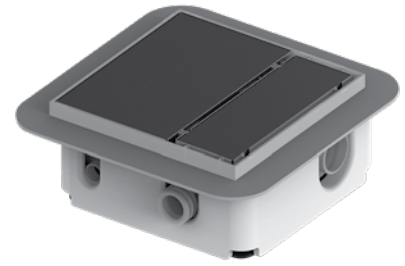

DESCRIPTION

Plancofix is a floor drainage pump that allows barrier-free or low entry showers to be fitted even where the lack of a gravity drain ruled out this option in the past. It must not be used for back flow protection.

Set into the screed, the Plancofix forms the floor drain in tiled showers. The incoming water is pumped to the nearest downpipe through a 1 inch pressure pipe. The transfer point into the downpipe must be at least 25 cm above the Plancofix.

The inflow from the shower can enter either directly from above through the floor drain, or from the side through a connecting branch.

The Plancofix plus has a smaller motor, which allows the a lower installation depth of 9 cm including the insulation tray. It is recommended for installation situations where only very low heights must be overcome.

PERFORMANCE

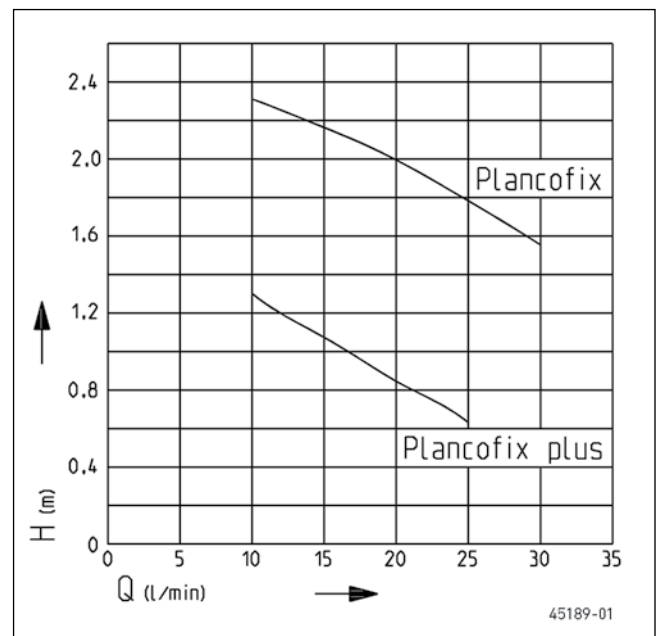

Type	Delivery head H [m]	0.5	1	1.3	1.5	2	2.3
Plancofix	Flow rate Q [l/min]				31	20	10
Plancofix plus		26	16	10			

We reserve the right to change specifications without notice. Pump performance is subject to ISO 9906 tolerances



PLANCOFIX

FLOOR DRAINAGE PUMPS

SCOPE OF SUPPLY

Ready to connect unit with tileable floor drain, synchronous motor with non-chlogging hydraulics, insulating tray for sound

compensation, height adjustment feet and ready-prepared for connection to a sealing membrane.

MECHANICAL DATA

Pump	Horizontal, single-stage	Pressure outlet	1" IG
Mounted circuit	Yes		

ELECTRICAL DATA

Voltage	1/N/PE~230 V	Winding thermostat	Yes
Power line	5m H05VV-F	Motor protection	Installed in the winding
Wires	3G0,75 GR	Plug	Without

PLANCOFIX

Type	Code No.	Motor rating P1	Current	Weight
Plancofix	JP44685	65 W	0.44 A	3.7 kg
Plancofix plus	JP47014	30 W	0.20 A	4.0 kg

Dimensions Plancofix / Plancofix plus (mm)

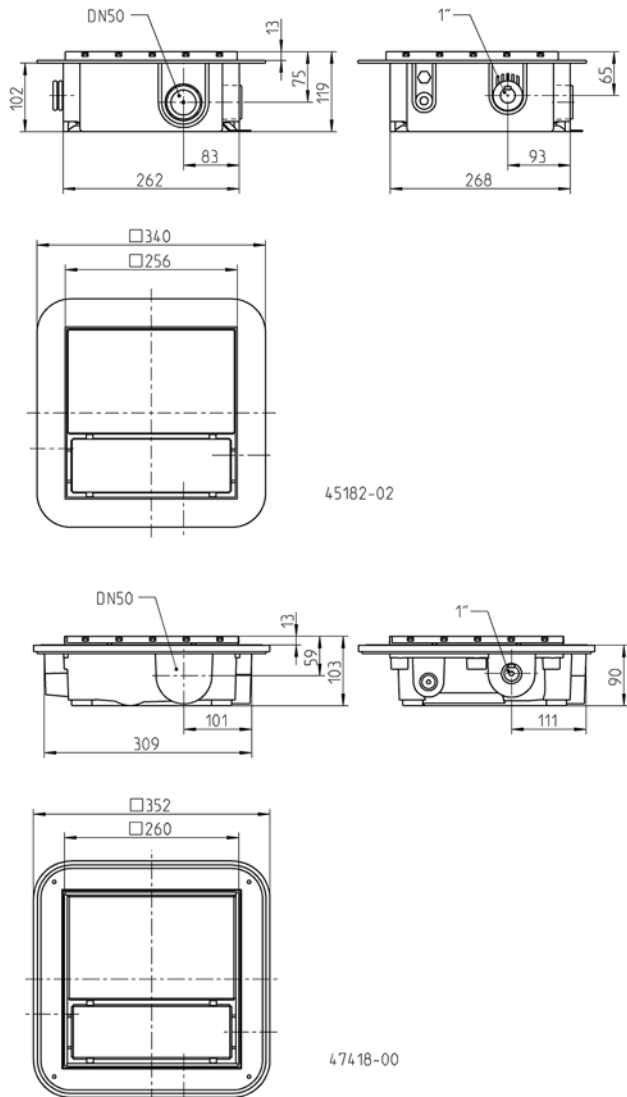

Example of installation

