

JUNG PUMPEN HEBEFIX PLUS DRAINAGE LIFTING STATION

APPLICATION

The Hebefix plus lifting station is an easily installed appliance for disposing of faeces-free waste water above and below the local back pressure level. Thanks to the small depth of its tank, it can be used in all commercial pre-wall systems. Its attractive design and intelligent technology also allow it to be fitted directly under a washbasin or in any other location. All grey water producers such as washbasins, showers, bathtubs, sinks, washing machines, etc. can be connected **(max three applications at the same time)**.

The grey water is pumped to the nearest downpipe through a small-dimensioned pressure pipe (left or right side).

Hebefix plus can be used wherever an additional bathroom or kitchen is required as part of renovation or conversion work.

For acoustic failure message, the Hebefix plus contains a runtime monitoring with alarm and a potential-free alarm contact.

The unit is supplied with a submersible pump mounted (U3 variant) which is ready to be plugged to a safety socket and operates fully automatically as soon as waste water starts to flow in. When installed in bathrooms and shower rooms, the corresponding German VDE regulations must be observed.

A sufficiently large inspection opening has to be provided for installation and servicing work (accessory). The unit is in conformity with the specifications of the German European standard EN 12050.



Hebefix plus (pump included in the scope of supply)

- Unit for pre-wall installation or direct connection
- Quiet
- Ready to connect
- Easy to maintain
- Pressure-tight
- Runtime monitoring with acoustic alarm and potential-free alarm contact
- High-quality plastic tank (ABS)

PERFORMANCE

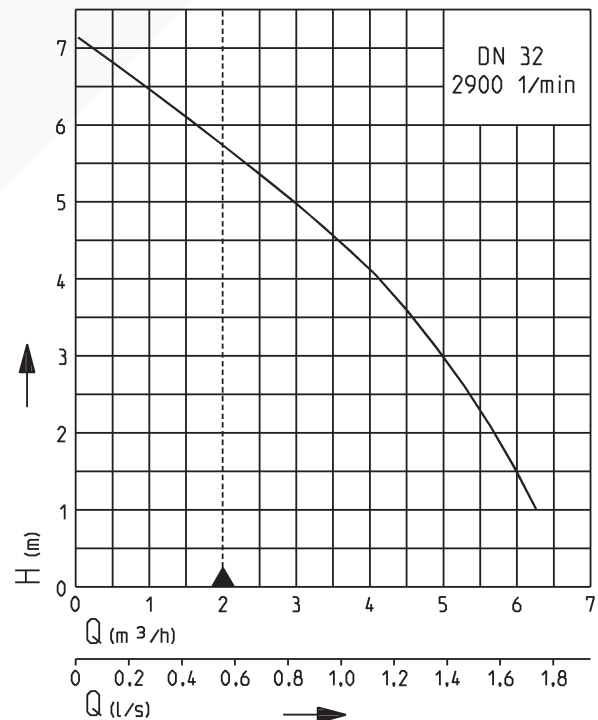

4 27945-00

We reserve the right to change specifications without notice Pump performance is subject to ISO 9906 tolerances

The minimum flow velocity in the pressure piping must be 0.7 m/s according to EN 12056. This data is represented in the performance curve as a limit of application.

JUNG PUMPEN HEBEFIX PLUS

DRAINAGE LIFTING STATION

HEBEFIX PLUS

Type	Height x Width x Depth	Cable	Weight approx.	Code no.
Hebefix plus	411 x 425 x 183 mm	1.5 m	7.0 kg	JP44544
Accessories:				
Installation kit for the inspection opening (flexibly adjustable to the tiles, 500 x 500 mm min.)				JP41075
Stop valve 1¼"				JP44785

PERFORMANCE

Type	Delivery head H [m]	1	2	3	4	5	6
Hebefix plus	Flow rate Q [m ³ /h]	6.5	5.5	5.0	4.0	3.0	1.5

ELECTRICAL DATA

Type	Type of current	Voltage Volt	Motor rating kW		RPM min ⁻¹	F.L.C. Ampere	Motor protection	Plug
			P ₁	P ₂				
Hebefix plus	1-phase	1/N/PE-230	0.32	0.20	2720	1.4	in the winding	Safety-

Mounting arrangement

Vertical pressure pipe with swing-type check valve and loop to be passed above the locally defined back pressure level.

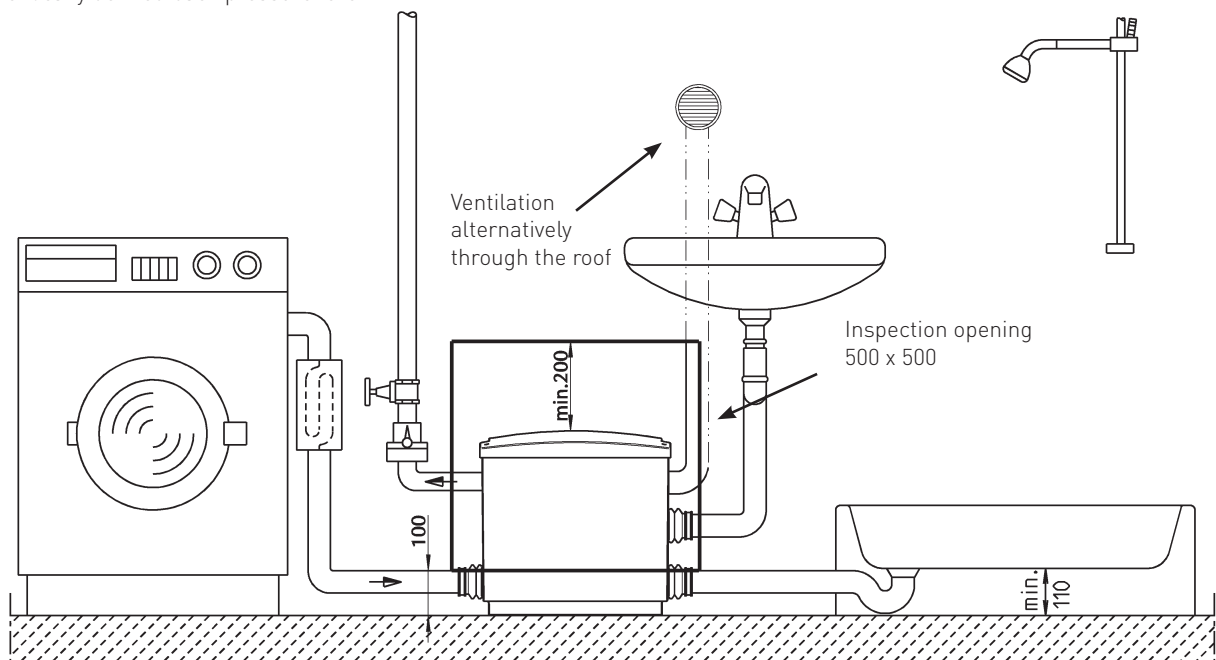

44590-01

JUNG PUMPEN HEBEFIX PLUS

DRAINAGE LIFTING STATION

Mounting instructions

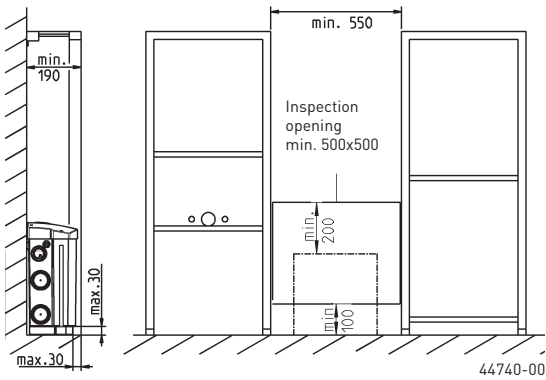

Hebefix plus can be combined with all commercially available pre-wall systems. The distances shown between the elements must be observed. Rails mounted on the floor for the alignment of several elements can be placed underneath the tank to save space.

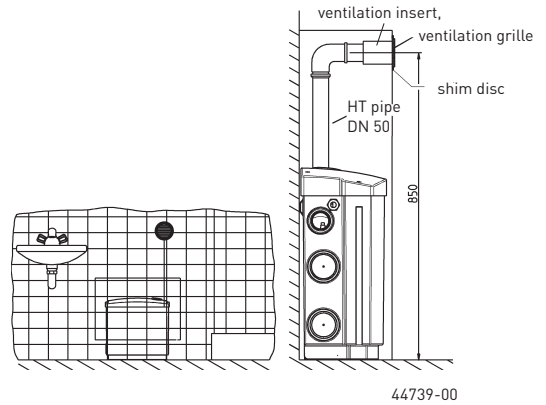

A ventilation system is imperative for operation. The installation method shown prevents moisture from developing behind the pre-wall. The Hebefix plus comes complete with all the special components required.

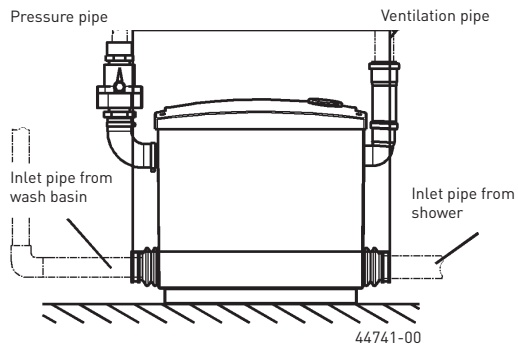

The system is placed in the installation space through the inspection opening and flexibly connected to the inlet pipes using the collars and clamps.

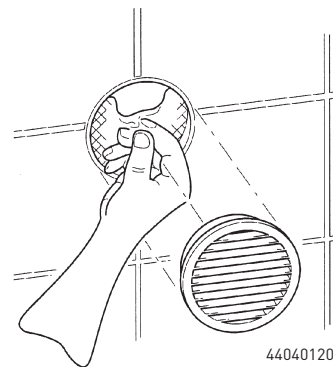

To change the activated carbon filter in the appliance's venting system, only the push-fit ventilation grille needs to be removed.

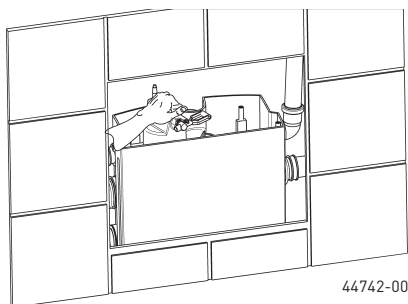

The pump can be taken out once the tank cover has been removed.

JUNG PUMPEN HEBEFIX PLUS

DRAINAGE LIFTING STATION

TECHNICAL DATA

Type

Tank complete, approx. 19l, with ready installed U3-type submersible pump with 10 mm free passage and hydraulics in EIP technology with open 5-impeller wheel, pressure drain bend of the tank made of elastomer with connection socket for pressure pipe (made of PVC, PP or PE) DN 32 with a diam. of 40 mm and 1 x 40 mm diameter. 4 x Inlet connections - diam. 50 mm. Connection to the appliance's nozzles with elastic connection collars.

Pump

Vertical, single stage, completely submersible, IP 68 enclosure type, insulation class B, motor thermostat for safety shut-off in case of overtemperature with automatic start-up system when sufficiently cooled, automatic circuit, moisture-sealed cable inlet to protect the pump in case of cable damage, permanent operation possible due to motor jacket cooling.

Level control

Automatic float switch, alarm system.

Materials

Motor housing and shaft made of stainless steel, tank, pump housing and impeller made of plastic, collars and outlet elbow made of elastomer.

Seal

Shaft seal ensured by shaft sealing rings and intermediate oil chamber, safe to run dry.

Scope of supply

Unit including pump according to the German European standard EN 12050, ready-to-connect with cable and plug, complete with collars, outlet elbow, swing-type checkvalve 1¼", transition nipple, ventilation insert, activated carbon filter, clamps and fastening material.



Dimensions Hebefix plus (mm)

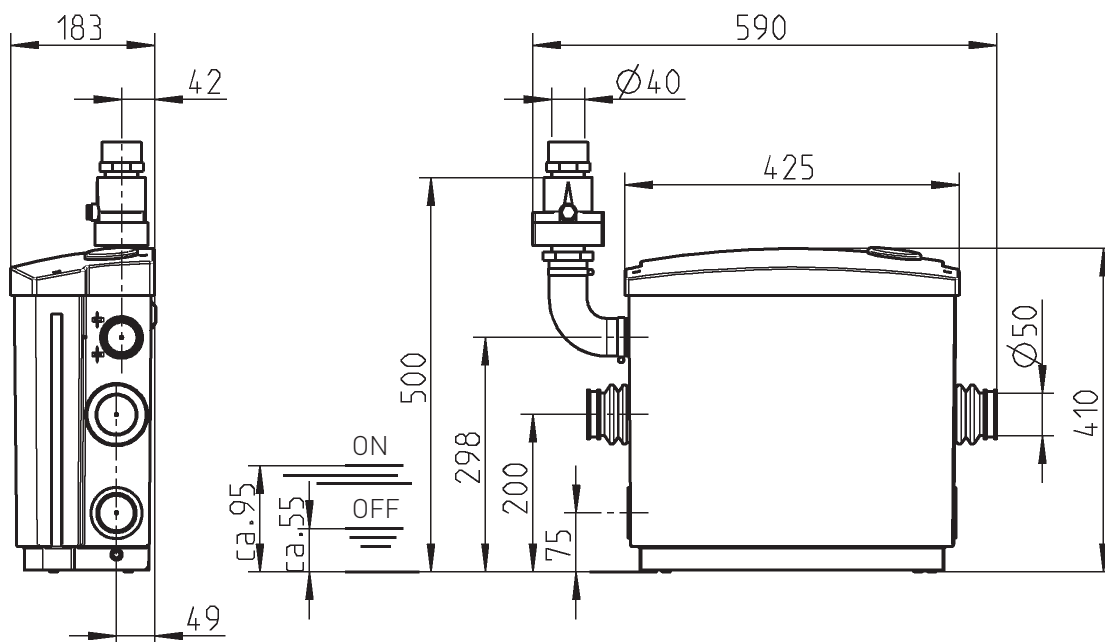

44589-00