

JUNG PUMPEN COMPLI 1200 SEWAGE LIFTING STATIONS

APPLICATION

With their performance graduations, the compli 1200 lifting stations has been designed for larger storage capacities, if wastewater of several residential units or wastewater from commercial enterprises, for example, have to be disposed of. During the design work, special attention was given to easy handling, space-saving erection and uncomplicated installation.

A fitting (to be provided by the customer) can be used at the rear inlet port of the stage housing to mount the unit variably in height (560 to 700 mm) as well as capable of rotating (180°).

The submersible unit is permitted for general use in areas subject to flooding without requiring additional outlay. The control unit has to be fitted in a well ventilated flood-proof room.

The construction with PE tank has freely accessible drains and a clamp-type inlet flange for easy installation. The top-mounted cleaning opening and the easy replaceability of the pre-mounted pumps also ensure time-saving servicing. Duplex systems have two pump units on one tank which are switched alternately or, if and when required, they are operated both in order to cope with peak load or reserve operation. This automatic switching sequence increase safety in particular for use in commercial or public buildings, and is always required in keeping with German / European standard DIN EN 12056-4, when the wastewater inflow must not be interrupted.

For application areas with special obligations for fire protection like airports or underground railways we recommend our sewage liftings stations in stainless steel on request.



Duplex units compli 1200

- Ready to connect
- Submersible
- Height-variable inlet
- Clamp-type inlet flange made of stainless steel
- Duplex swing-type check valve
- PE tank

PERFORMANCE

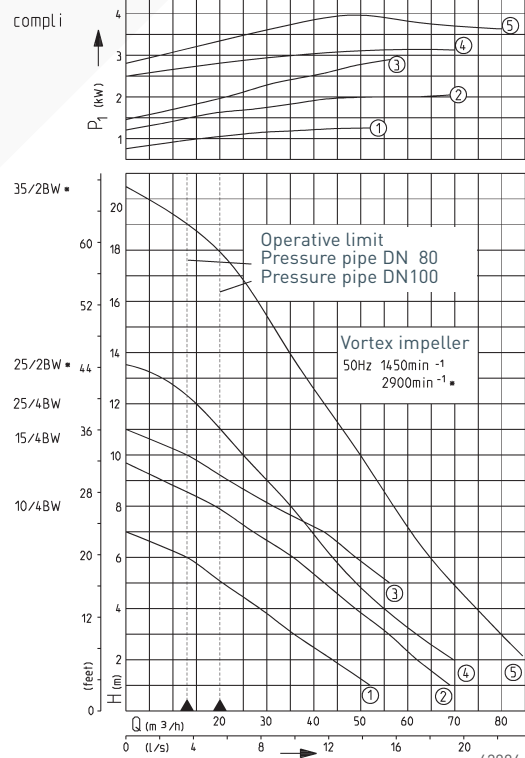

We reserve the right to change specifications without notice

Pump performance is subject to ISO 9906 tolerances

The minimum flow velocity in the pressure piping must be 0.7 m/s according to EN 12056. This data is represented in the performance curve as a limit of application.

JUNG PUMPEN COMPLI 1200

SEWAGE LIFTING STATIONS

SEWAGE DISPOSAL UNITS

Type	Tank capacity l	Inlet height mm	Free passage mm	Clamp-type inlet flange	Connecting flange PN 10	for connecting pipe	Ventilation	Weight approx.	Code No.
compli 1210/4 BW	350	560	70	DN 150	DN 80	DN 100	DN 70	145,0 kg	JP09168
compli 1215/4 BW	350	up to	70	DN 150	DN 80	DN 100	DN 70	145,0 kg	JP09169
compli 1225/4 BW	350	700	70	DN 150	DN 80	DN 100	DN 70	145,0 kg	JP09170
compli 1225/2 BW	350	variable	70	DN 150	DN 80	DN 100	DN 70	149,0 kg	JP09171
compli 1235/2 BW	350		70	DN 150	DN 80	DN 100	DN 70	158,0 kg	JP09172

PERFORMANCE

Type	Delivery head H [m]	1	2	3	4	5	6	7	8	9	10	11	13	15	17
compli 1210/4 BW	Flow rate Q [m³/h]	52	44	37	29	22	13								
compli 1215/4 BW		69	62	56	49	42	36	27	19						
compli 1225/4 BW						56	49	42	32	22	13				
compli 1225/2 BW		69	64	58	52	47	42	37	33	28	23	20	8		
compli 1235/2 BW		85	80	75	71	66	62	57	54	50	47	44	36	30	21

ELECTRICAL DATA

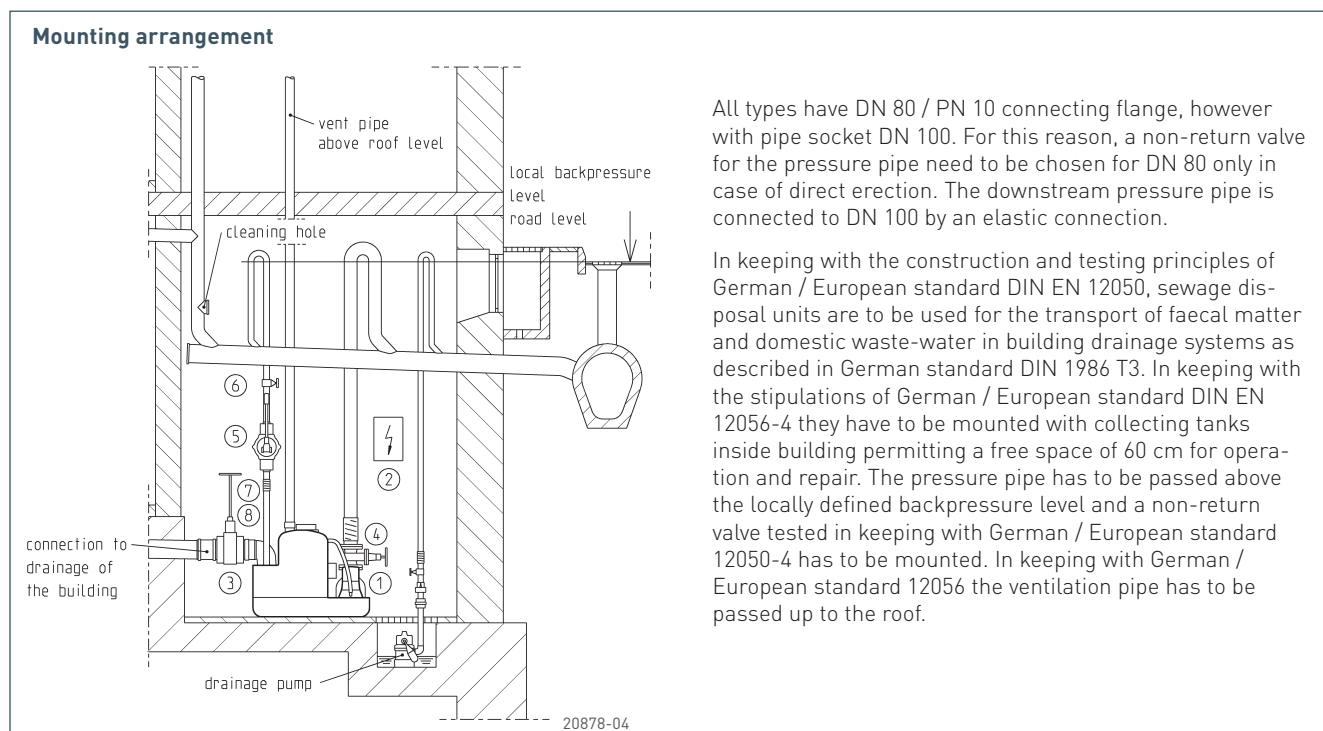

Type	Type of current	Voltage Volt	Motor rating kW		Current Ampere	RPM min. ⁻¹	Cable (4 m) Tank control	Cable (1.5 m) Control plug	Plug
			P ₁	P ₂					
compli 1210/4 BW	3-phase	3/N/PE-400	1.3	1.0	2.8	1451	H07RN-F-6 G 1.5	H05VV-F-5 G 1.5	CEE-
compli 1215/4 BW	3-phase	3/N/PE-400	2.2	1.7	3.9	1405	H07RN-F-6 G 1.5	H05VV-F-5 G 1.5	CEE-
compli 1225/4 BW	3-phase	3/N/PE-400	3.0	2.2	5.1	1363	H07RN-F-6 G 1.5	H05VV-F-5 G 1.5	CEE-
compli 1225/2 BW	3-phase	3/N/PE-400	3.3	2.6	5.4	2812	H07RN-F-6 G 1.5	H05VV-F-5 G 1.5	CEE-
compli 1235/2 BW	3-phase	3/N/PE-400	4.8	4.0	8.2	2886	H07RN-F-6 G 1.5	H05VV-F-5 G 1.5	CEE-



JUNG PUMPEN COMPLI 1200

SEWAGE LIFTING STATIONS

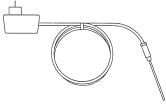
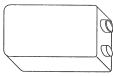
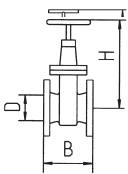
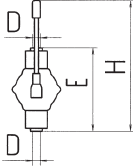
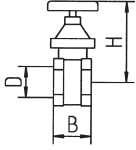
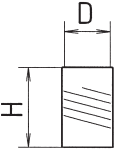
ACCESSORIES

		Code No.												
	1 Seal leak detector DKG (for 25/2 BW and 35/2 BW) Please account one seal leak detector per pump	JP44900												
	2 Rechargeable battery for control for mains-independent alarm	JP44850												
	3 PVC sluice valve (with two pipe sockets) for 6" inlet (DN 150) PN 2.5	<table style="width: 100%; border-collapse: collapse;"> <tr> <td style="text-align: center; width: 15%;"><u>H</u></td> <td style="text-align: center; width: 15%;"><u>B</u></td> <td style="text-align: center; width: 15%;"><u>E</u></td> <td style="text-align: center; width: 15%;"><u>F</u></td> <td style="text-align: center; width: 15%;"><u>D</u></td> <td style="width: 20%;"></td> </tr> <tr> <td style="text-align: center;">660</td> <td style="text-align: center;">450</td> <td style="text-align: center;">110</td> <td style="text-align: center;">105</td> <td style="text-align: center;">160</td> <td style="text-align: right;">JP28591</td> </tr> </table>	<u>H</u>	<u>B</u>	<u>E</u>	<u>F</u>	<u>D</u>		660	450	110	105	160	JP28591
	<u>H</u>	<u>B</u>	<u>E</u>	<u>F</u>	<u>D</u>									
660	450	110	105	160	JP28591									
4 Sluice valve* for 3" pressure side (DN 80), PN 10, DIN EN 1171	<table style="width: 100%; border-collapse: collapse;"> <tr> <td style="text-align: center; width: 15%;"><u>H</u></td> <td style="text-align: center; width: 15%;"><u>B</u></td> <td style="text-align: center; width: 15%;"><u>D</u></td> <td style="width: 55%;"></td> </tr> <tr> <td style="text-align: center;">315</td> <td style="text-align: center;">180</td> <td style="text-align: center;">DN 80</td> <td style="text-align: right;">JP00639</td> </tr> </table>	<u>H</u>	<u>B</u>	<u>D</u>		315	180	DN 80	JP00639					
<u>H</u>	<u>B</u>	<u>D</u>												
315	180	DN 80	JP00639											
	6 Hand diaphragm pump for emergency purposes (up to H_{geod} 15 m)	<table style="width: 100%; border-collapse: collapse;"> <tr> <td style="text-align: center; width: 15%;"><u>H</u></td> <td style="text-align: center; width: 15%;"><u>E</u></td> <td style="text-align: center; width: 15%;"><u>D</u></td> <td style="width: 55%;"></td> </tr> <tr> <td style="text-align: center;">ca. 640</td> <td style="text-align: center;">430</td> <td style="text-align: center;">1½"</td> <td style="text-align: right;">JP00255</td> </tr> </table>	<u>H</u>	<u>E</u>	<u>D</u>		ca. 640	430	1½"	JP00255				
<u>H</u>	<u>E</u>	<u>D</u>												
ca. 640	430	1½"	JP00255											
	7 Stop valve, 1½" (DN 40), PN 16	<table style="width: 100%; border-collapse: collapse;"> <tr> <td style="text-align: center; width: 15%;"><u>H</u></td> <td style="text-align: center; width: 15%;"><u>B</u></td> <td style="text-align: center; width: 15%;"><u>D</u></td> <td style="width: 55%;"></td> </tr> <tr> <td style="text-align: center;">125</td> <td style="text-align: center;">max. 60</td> <td style="text-align: center;">1½"</td> <td style="text-align: right;">JP44786</td> </tr> </table>	<u>H</u>	<u>B</u>	<u>D</u>		125	max. 60	1½"	JP44786				
<u>H</u>	<u>B</u>	<u>D</u>												
125	max. 60	1½"	JP44786											
	8 Elastic connection 1½" (DN 40), PN 4	<table style="width: 100%; border-collapse: collapse;"> <tr> <td style="text-align: center; width: 15%;"><u>H</u></td> <td style="text-align: center; width: 15%;"><u>D</u></td> <td style="width: 70%;"></td> </tr> <tr> <td style="text-align: center;">120</td> <td style="text-align: center;">50</td> <td style="text-align: right;">JP44777</td> </tr> </table>	<u>H</u>	<u>D</u>		120	50	JP44777						
<u>H</u>	<u>D</u>													
120	50	JP44777												
	9 Clamp 1½"	JP44763												

* with screws and seal

JUNG PUMPEN COMPLI 1200

SEWAGE LIFTING STATIONS

TECHNICAL DATA

Pump

Vertical, single-stage, submersible, vortex impeller, spiral casing with vertical DN 100 outlet, flanged to PE tank with cleaning opening and pre-mounted duplex swing-type check valve.

Bearing

Common shaft for pump and motor, grease-packed ball bearing.

Motor

Submersible, IP 68 type of protection, insulation class F, winding thermostats for the protection of the drives against overheating, automatic start-up by three-contact circuit with reed contacts and control. Connection to mains by 16 A CEE plug, S 3 type of operation in keeping with German standard VDE.

Seal

Duplex 10/4-25/4 BW radial shaft sealing ring, 25/2 BW and 35/2 BW silicon carbide mechanical seal independent of rotation and safe to run dry. Oil chamber with duplex radial shaft sealing ring

towards the motor compartment. Connection possibility for seal leak detector on 25/2 BW and 35/2 BW.

Materials

Tank made of corrosion resistant and environmentally compatible polyethylene; pump and motor housing, single-vane impeller and duplex swing-type check valve made of wear-resistant grey cast iron; shaft made of stainless steel (versions 10/4-25/4 BW) or completely covered towards the media (version 25/2 and 35/2 BW); rubber inlet hose.

Scope of supply

Ready-to-connect sewage disposal unit in keeping with German / European standard DIN EN 12050 with DN 150 clamp-type inlet flange, pre-mounted submersible pump (two pumps in duplexsystem) and DN 80 connecting flange with pipe unit. Ø110, pre-mounted duplex swing-type check valve, one elastic connection each with clamps for plastic pressure pipe and ventilation pipe, automatic level control.

Control unit (IP 44 type of protection) with motor protection, contactors, transformer, mains-independent alarm system and potential-free make contact for collective failure messages, with optical display of sense of rotation, alarm and operation as well as two manual-0-automatic switch. With automatic changeover system and peak load function. To be fitted with a micro-processor control as well upon request.

Cable: between tank and control 4 m, between control and plug 1.5 m. Accessories to be ordered according to mounting drawing.



DIMENSIONS COMPLI 1200 (MM)

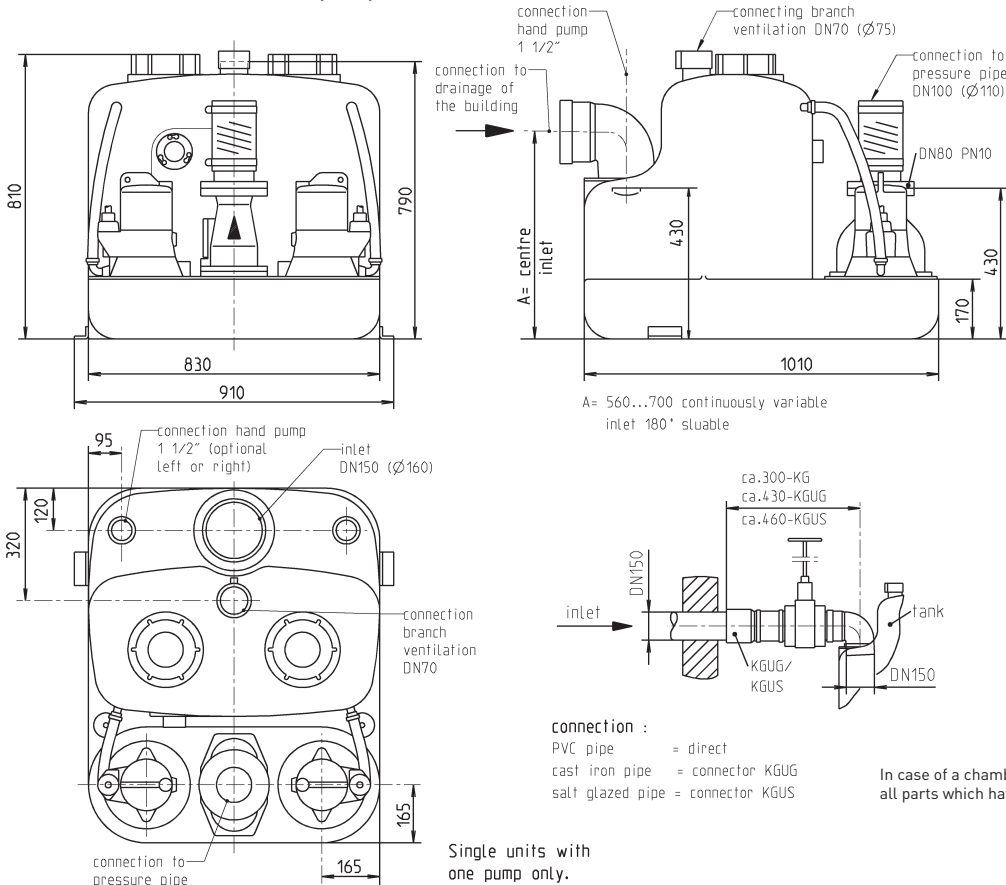

42959-01