

# HEBEFIX

## ABOVE FLOOR TANK



- Disposal of dirty water from hand basin, shower, bathtub, washing machine
- Condensate from condensing boilers
- Backwash water from softeners
- Easy opening of the cover without dismantling a siphon or an inlet pipe
- Swing-type check valve and activated carbon filter are scope of supply
- Wall or floor installation
- Pressure pipe on the right or left side
- Alarm system possible

### DESCRIPTION

The Hebefix above-floor tank is the ideal solution if a washbasin or sink is to be installed and there is no waste water pipe nearby. It is quick to install and offers ideal solutions in combination with the U3KS, U3KS special or U5KS drainage pumps.

The drainage pump intended for the Hebefix is connected to the prepared pipe connection and automatically pumps the incoming grey water to the next disposal pipe. The tank has four inlet sleeves. This means that a drain can be created at any desired location, even below the backwater level, without costly bricklaying work. By means of the lower additional inlets on both sides (H=100 mm) and a special float for lower switching heights, a backflow-proof shower can be connected.

The supplied activated carbon filter reduces odours. The installation of an alarm unit is recommended. The automatic alarm AGR or AWR (alarm device with washing machine cutoff) signalizes an unacceptably high water level and the AWR switches off the connected machine. If the special float is installed at the same time, the special fastener for alarm is required.

### PERFORMANCE

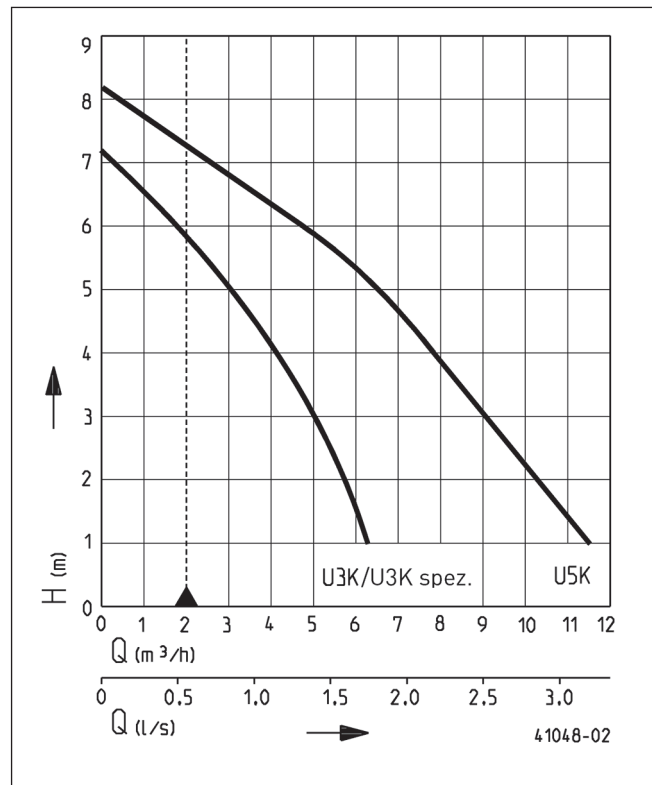

We reserve the right to change specifications without notice. Pump performance is subject to ISO 9906 tolerances

The minimum flow velocity in the pressure piping must be 0.7 m/s according to EN 12056. This data is represented in the performance curve as a limit of application.



# HEBEFIX

## ABOVE FLOOR TANK

### SCOPE OF SUPPLY

Plastic tank without pump with integrated connection hose, clamps, swing-type check valve R32, activated carbon filter,

rubber feet and wall attachment parts. The unit is in conformity with the specification of EN 12050.

### MECHANICAL DATA

Tank capacity	26 l	Weight	3.2 kg
---------------	------	--------	--------

### HEBEFIX

Type	Code No.
Hebefix	JP50210

### POSSIBLE PUMPS

Hebefix	U5KS
U3KS/U3KS-spezial	

### Dimensions (mm)

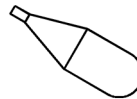
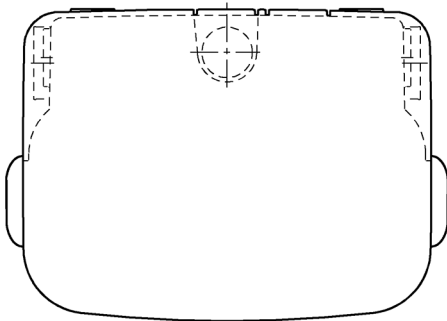
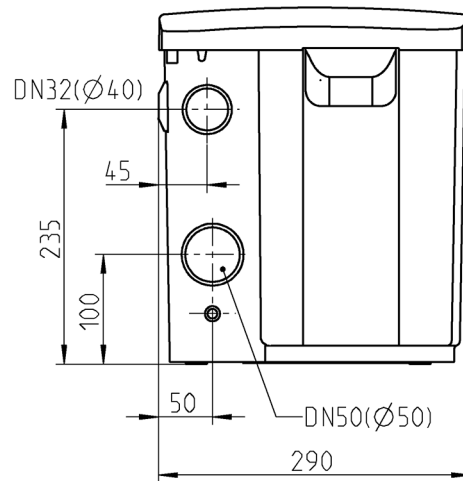
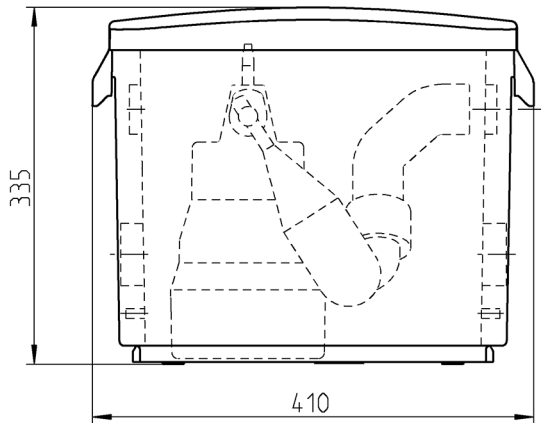

	ON	OFF
U3	220	110
U5	245	140

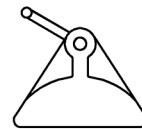

	ON	OFF
U3	110	50

49518-00

# HEBEFIX

## ABOVE FLOOR TANK

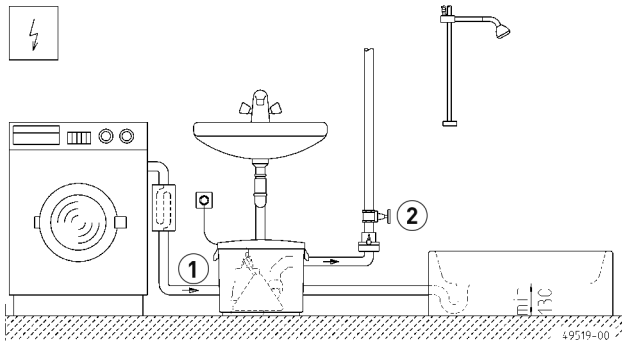

Example of installation Hebefix (floor mounted)



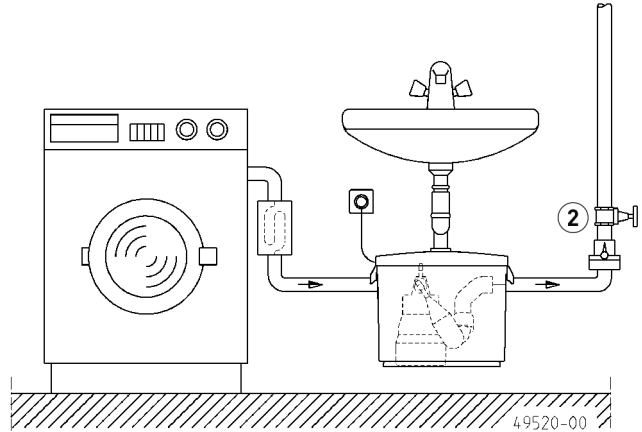

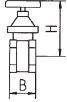

Hebefix (wall mounted)



### MECHANICAL ACCESSORIES

				Code No.
	<b>1</b> Special float	for lower switching points		JP44795
	<b>2</b> Stop-valve	1/4" (DN 32), PN 16	110x60 (HxB)	JP44785
	Ball valve	1/4", PVC, for aggressive media	105x155 (HxB)	JP46111

### ELECTRICAL ACCESSORIES

			Code No.
	<b>a</b> Alarm unit AGR	reed switch, mains dependent, potential-free contact, 3 m cable	JP44893
	Washing machine stop AWR	reed switch, mains dependent, 3 m cable	JP44897
	Fastener for alarm switch	(only U3KS, U5KS and U6KS with special float switch)	JP28191
	<b>b</b> Rechargeable battery	for mains-independent alarm	JP44850

# HEBEFIX

ABOVE FLOOR TANK